

Cooper & Co.

Cooper and Co

Iris book shelf

ASSEMBLY
INSTRUCTIONS

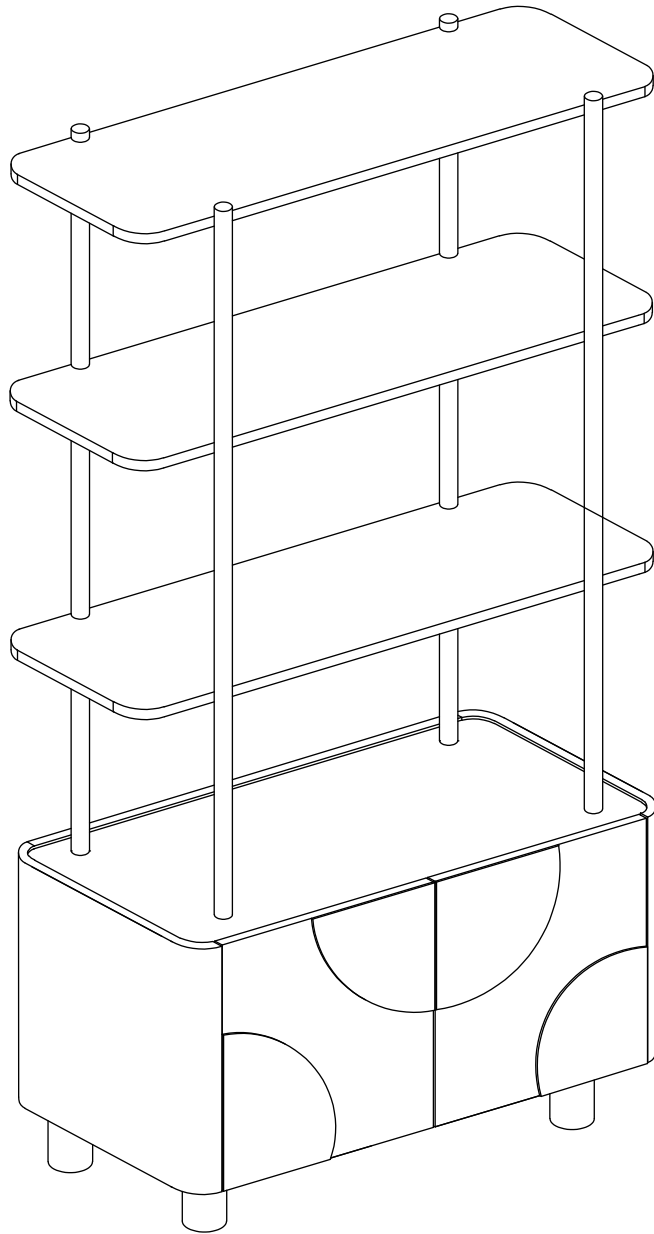

Cooper & Co.®

Cheers for making this yours!

Cooper & Co is your go-to source for homeware that's as stylish as it is affordable! With our carefully curated selection, we aim to bring you the best of both worlds, ensuring that you can create a space that reflects your personal style without breaking the bank.

We're on a mission to sprinkle some pizzazz into every home. Whether you're looking to transform your living room, kitchen, or bedroom into a masterpiece, fret not! With us, you don't have to sacrifice quality or design.

TIPS BEFORE YOU START

1. Sit back, take a deep breath, and get ready to dive into the laid-back world of furniture assembly. We've got your back with some simple instructions that will have you relaxing with your amazing new piece in no time.
2. Please check that all parts are present before you start the assembly of your furniture.
3. For ease and speed of assembly, we recommend that before you commence each step of the assembly, that you identify all the parts required for that step.
4. For larger items, please ensure that you have sufficient space and people to assemble your product safely.
5. We recommend that, where possible, all items are assembled near to the area in which they will be placed in use, to avoid moving the product unnecessarily once assembled.
6. For the protection of your furniture, we recommend that the product is placed on a protected surface during assembly to prevent any damage.
7. During assembly please take care not to over-tighten any fittings, as this may damage the product. Do not use power tools.
8. Always place the product on a flat, steady and stable surface.
9. Do not stand on the product. Do not use the product as a stepladder.
10. This product is intended for indoor, household use only as it is a non-industrial product.
11. Please use caution and care when lifting the product to avoid personal injury and/or product damage.

ASSEMBLY REQUIREMENTS

- 1m x 1m assembly space required. Give your furniture some breathing room!
- Approximately 2 hour assembly time. Remember, it's not a race, so take your time, enjoy the process.
- 2 x adults required, enlist the help of your favourite tag team.



USING CAM LOCK & QUICKFIT

QUICKFIT

Tighten quickfit until shoulder is flush with panel. Do not overtighten or undertighten.

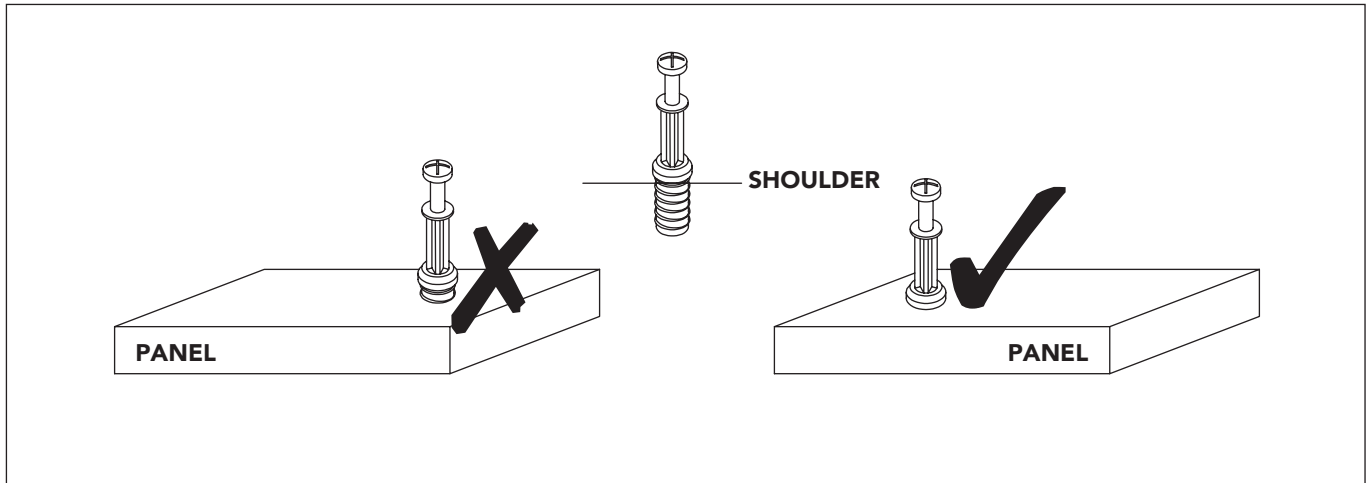

CAM LOCK

When fitting cam lock, ensure starting position is correct before you insert connecting quickfit.

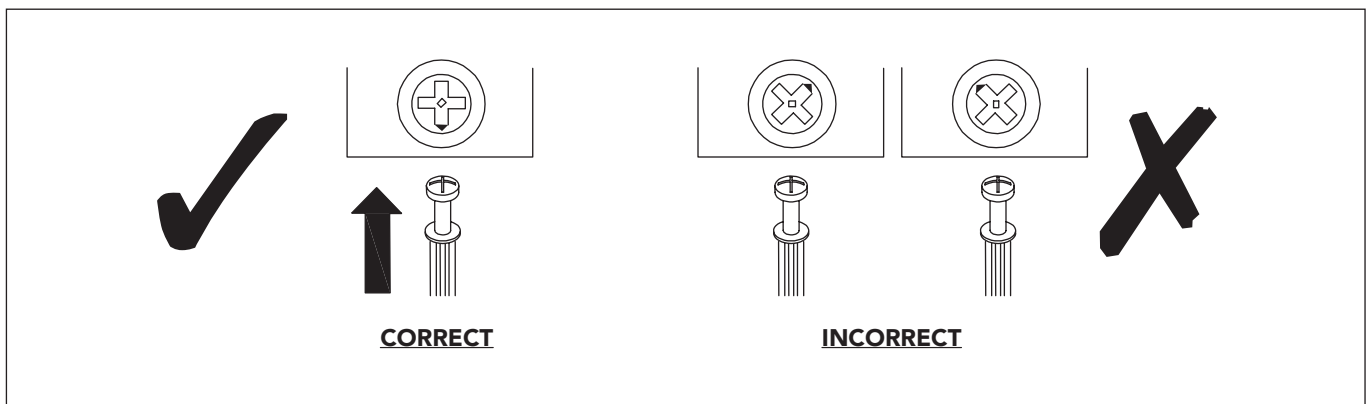



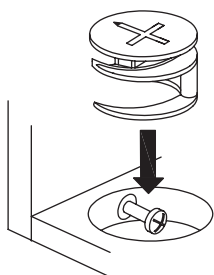

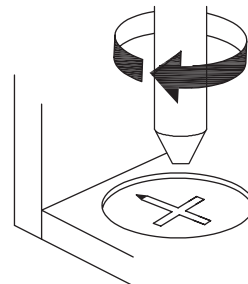

Quickfit head should be in the centre of the cam lock when the two panels are joined. Cam lock should be inserted before quickfit.



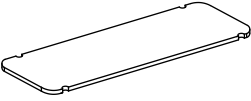
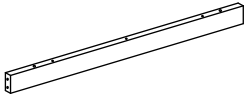
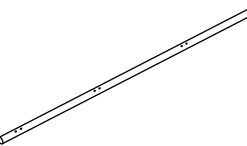
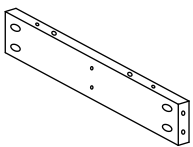
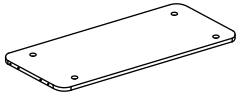
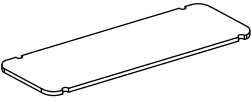
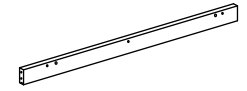

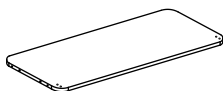
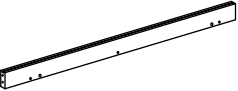
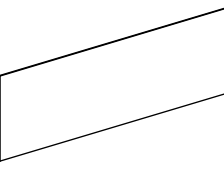
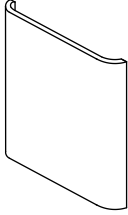
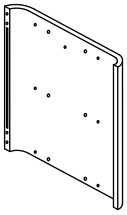
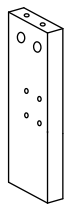
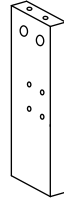



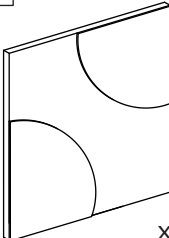
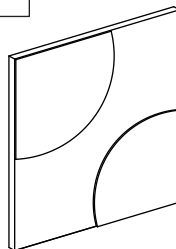
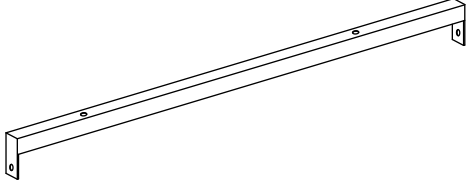



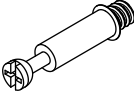

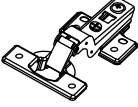

Turn cam lock clockwise to tighten.

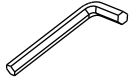
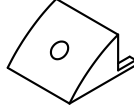

PARTS LIST

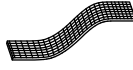
<p>1</p>  <p>x1</p>	<p>2</p>  <p>x3</p>	<p>3</p>  <p>x4</p>	<p>4</p>  <p>x6</p>	<p>5</p>  <p>x1</p>
<p>6</p>  <p>x2</p>	<p>7</p>  <p>x1</p>	<p>8</p>  <p>x1</p>	<p>9</p>  <p>x1</p>	<p>10</p>  <p>x1</p>
<p>11</p>  <p>x1</p>	<p>12</p>  <p>x1</p>	<p>13</p>  <p>x1</p>	<p>14</p>  <p>x1</p>	<p>15</p>  <p>x1</p>
<p>16</p>  <p>x1</p>	<p>17</p>  <p>x1</p>	<p>18</p>  <p>x4</p>	<p>19</p>  <p>x1</p>	<p>20</p>  <p>x1</p>
<p>21</p>  <p>x1</p>				

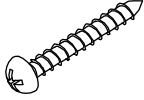
HARDWARE

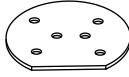
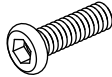
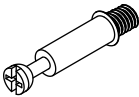
<p>A</p> <p>M6X35</p>  <p>x40</p>	<p>B</p> <p>M15X9.5</p>  <p>x64</p>	<p>C</p> <p>M8X30</p>  <p>x34</p>	<p>D</p> <p>M7X40</p>  <p>x8</p>
<p>E</p> <p>M4X14</p>  <p>x24</p>	<p>F</p>  <p>x4</p>	<p>G</p>  <p>x44</p>	<p>H</p> <p>M4X35</p>  <p>x29</p>
<p>I</p>  <p>x4</p>	<p>J</p> <p>M4X14</p>  <p>x4</p>	<p>K</p>  <p>x1</p>	<p>L</p>  <p>x4</p>
<p>M</p> <p>M3X16</p>  <p>x4</p>	<p>N</p>  <p>x20</p>	<p>O</p>  <p>x2</p>	<p>P</p>  <p>x2</p>
<p>Q</p> <p>M4X30</p>  <p>x2</p>	<p>R</p> <p>M6X14</p>  <p>x16</p>	<p>S</p>  <p>x4</p>	<p>T</p> <p>M6X25</p>  <p>x8</p>
<p>U</p> <p>M6X35</p>  <p>x24</p>			

ASSEMBLY INSTRUCTIONS

STEP 1

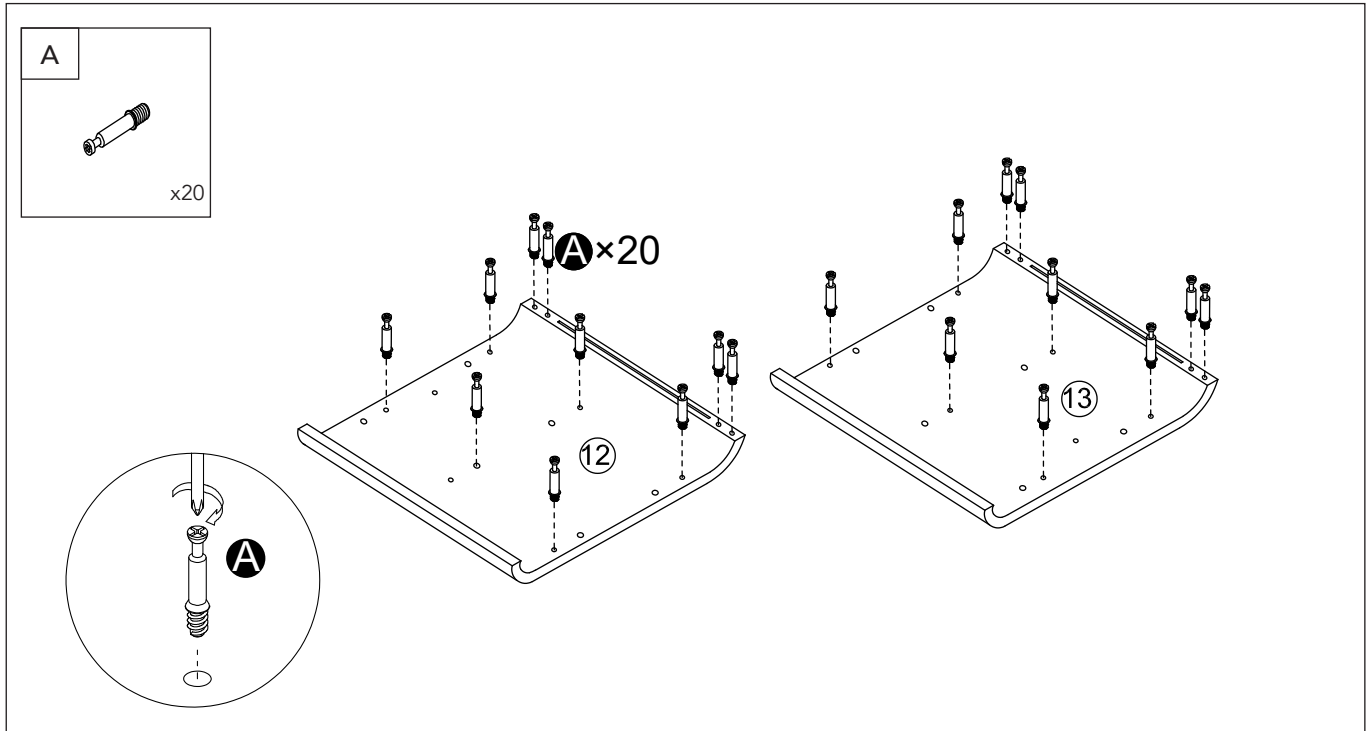

STEP 2

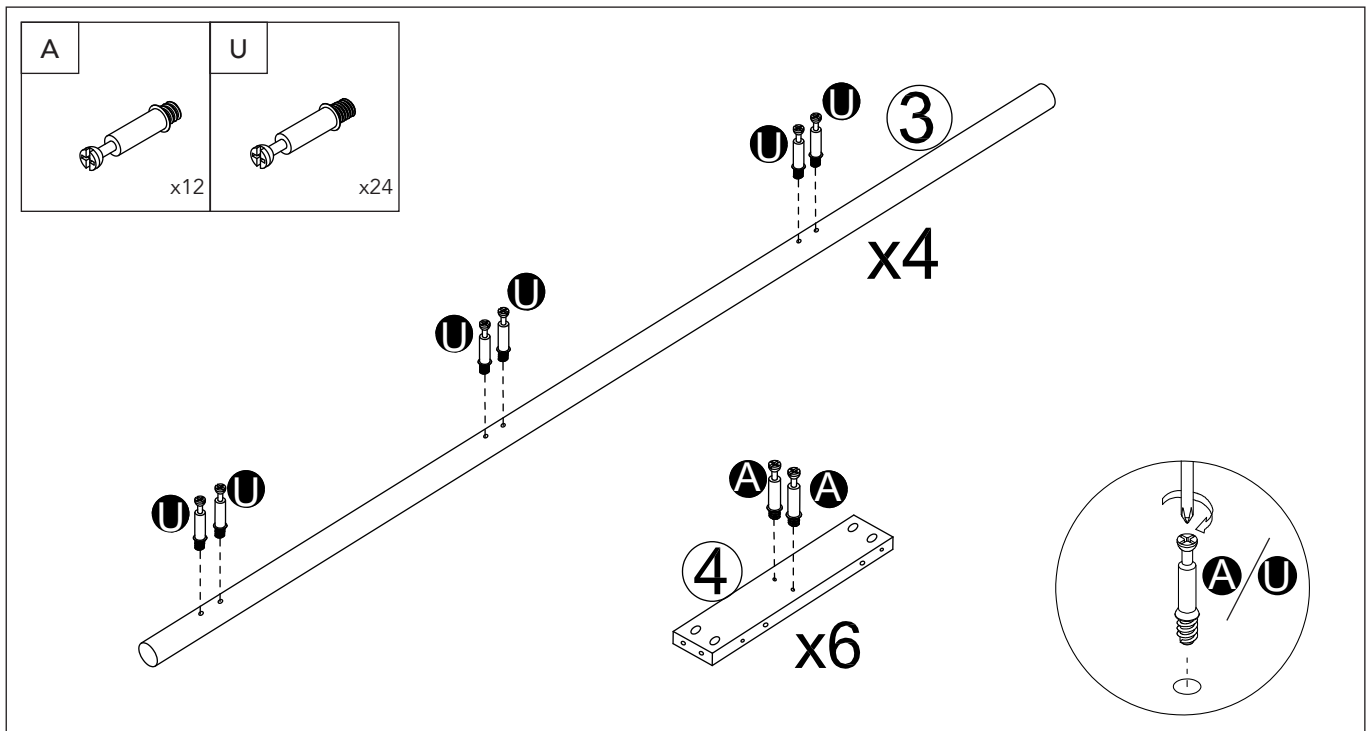

ASSEMBLY INSTRUCTIONS

STEP 3

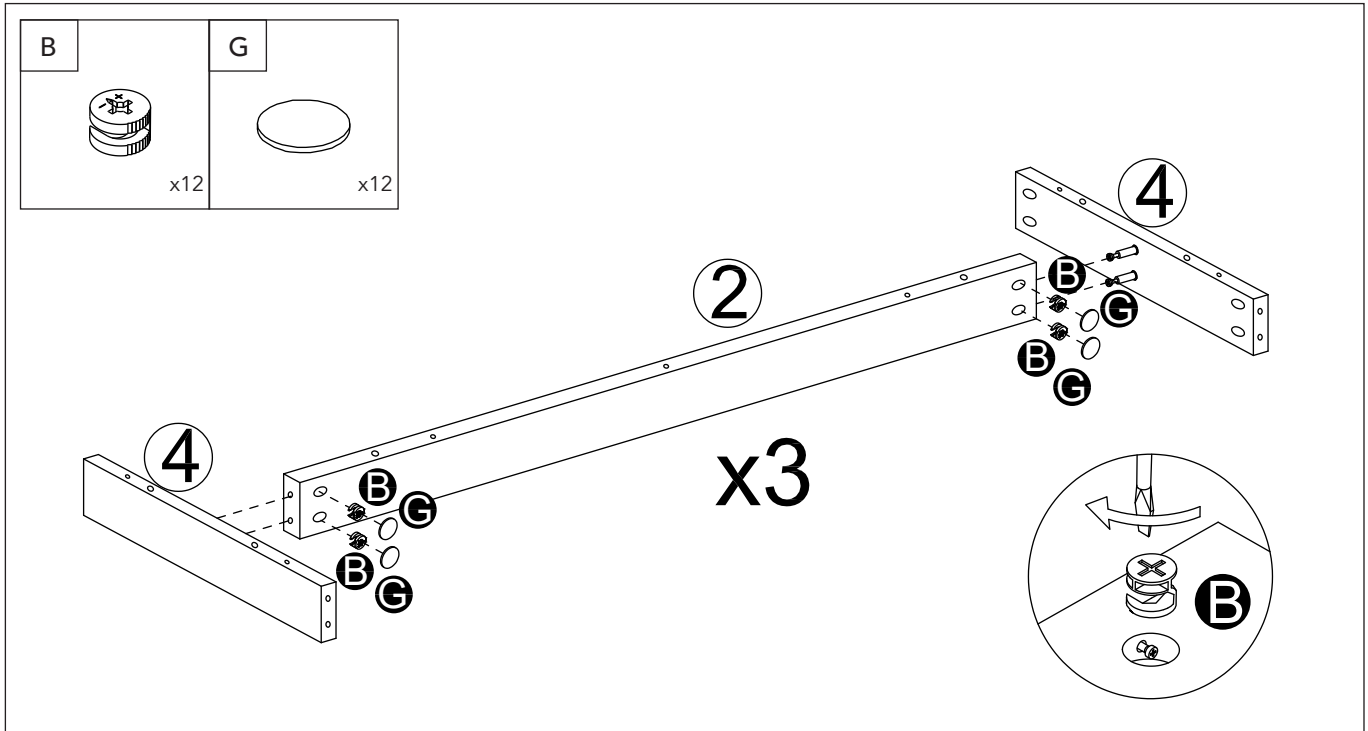

STEP 4

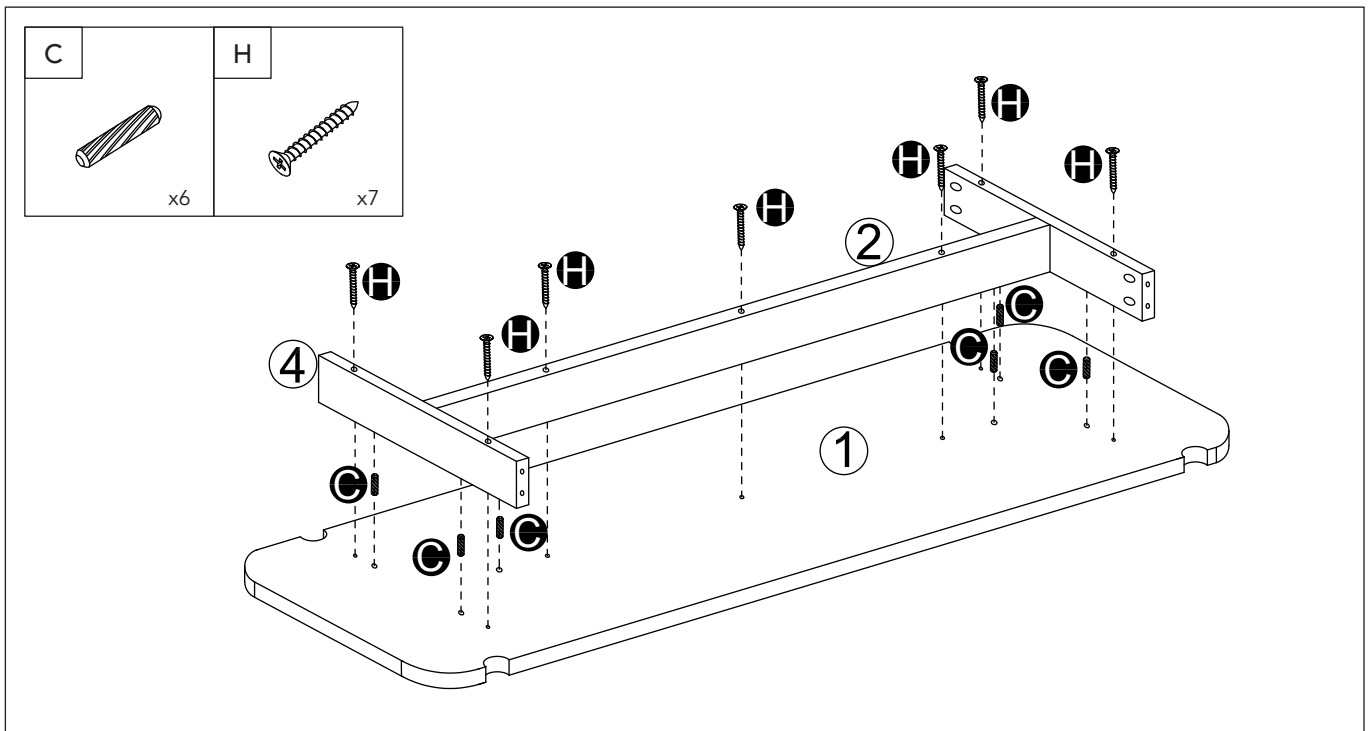

ASSEMBLY INSTRUCTIONS

STEP 6

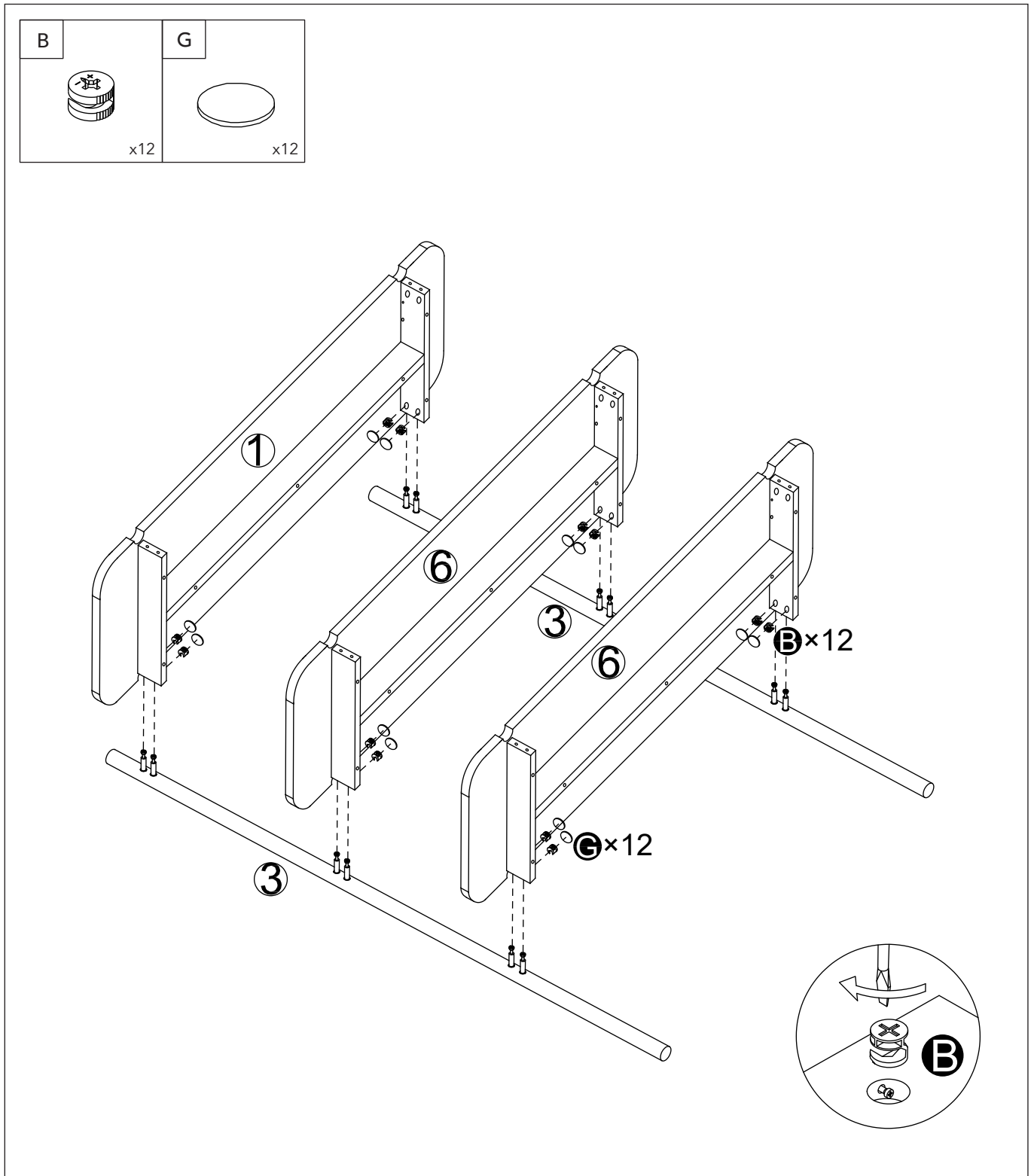

ASSEMBLY INSTRUCTIONS

STEP 7

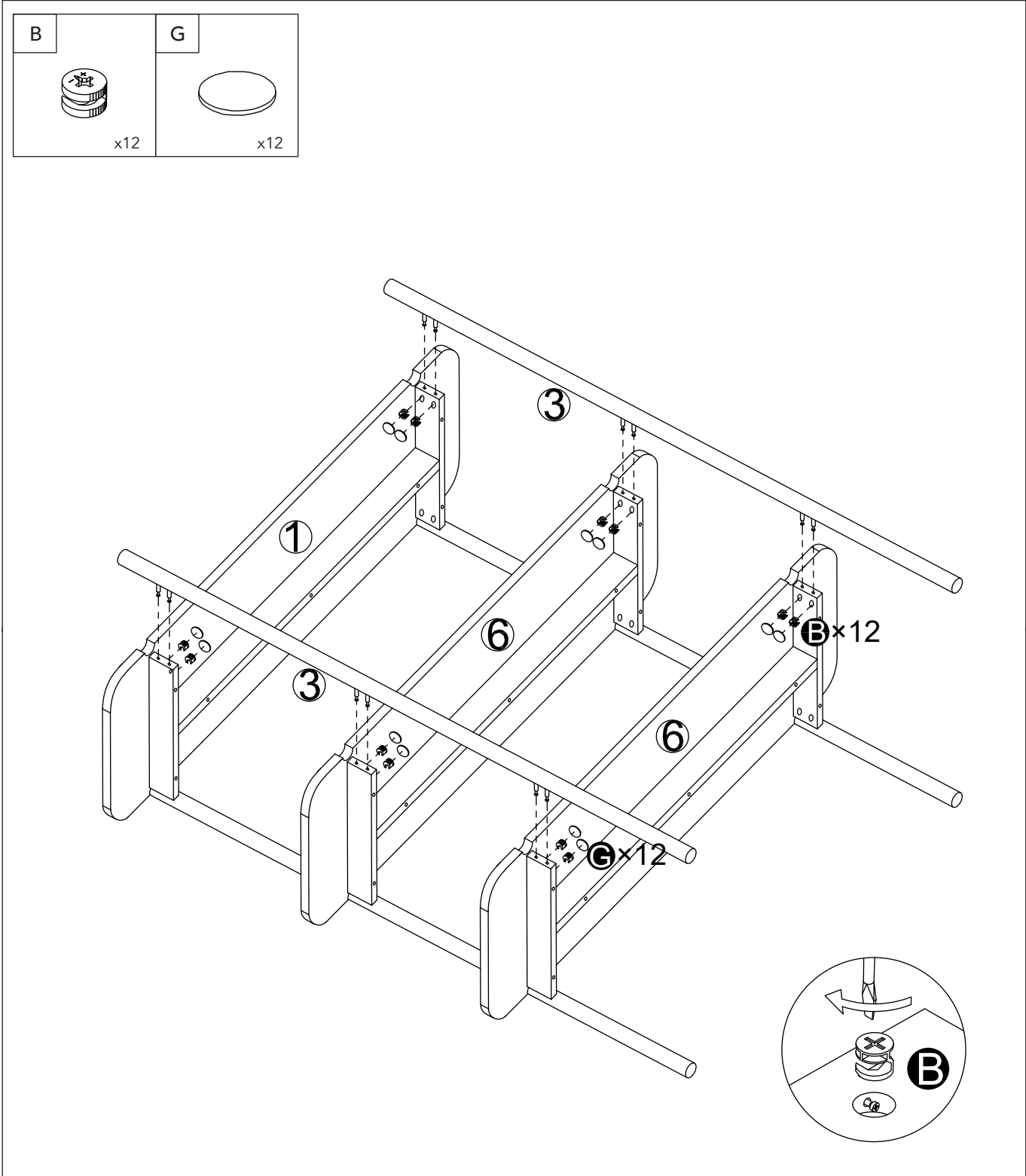

ASSEMBLY INSTRUCTIONS

STEP 8

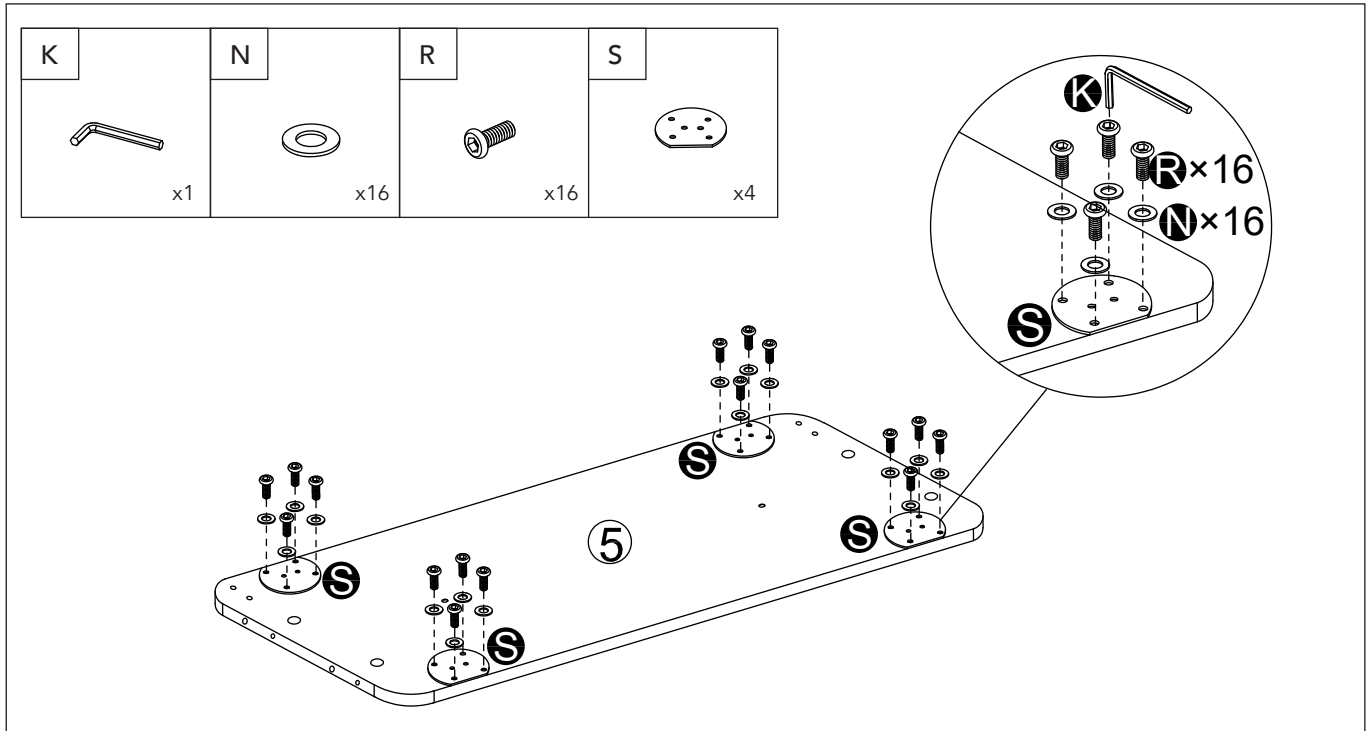

STEP 9

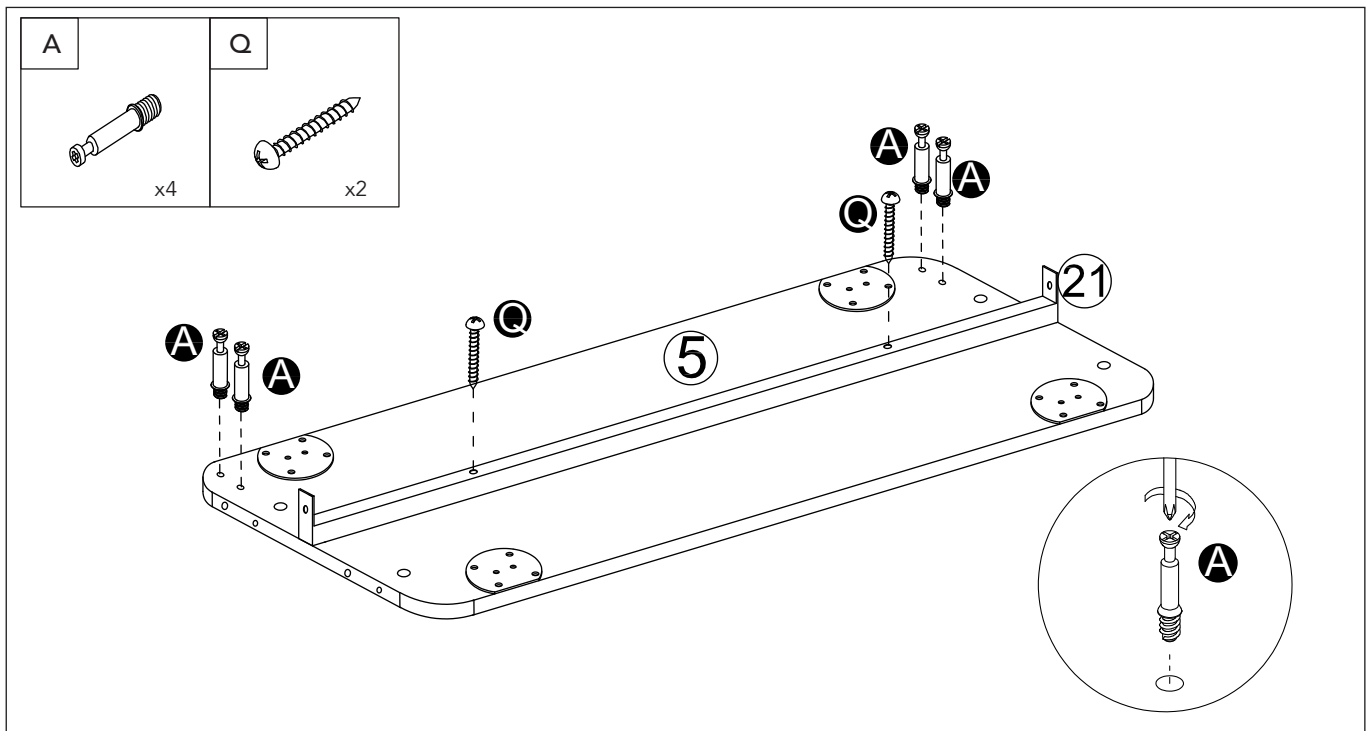

ASSEMBLY INSTRUCTIONS

STEP 10

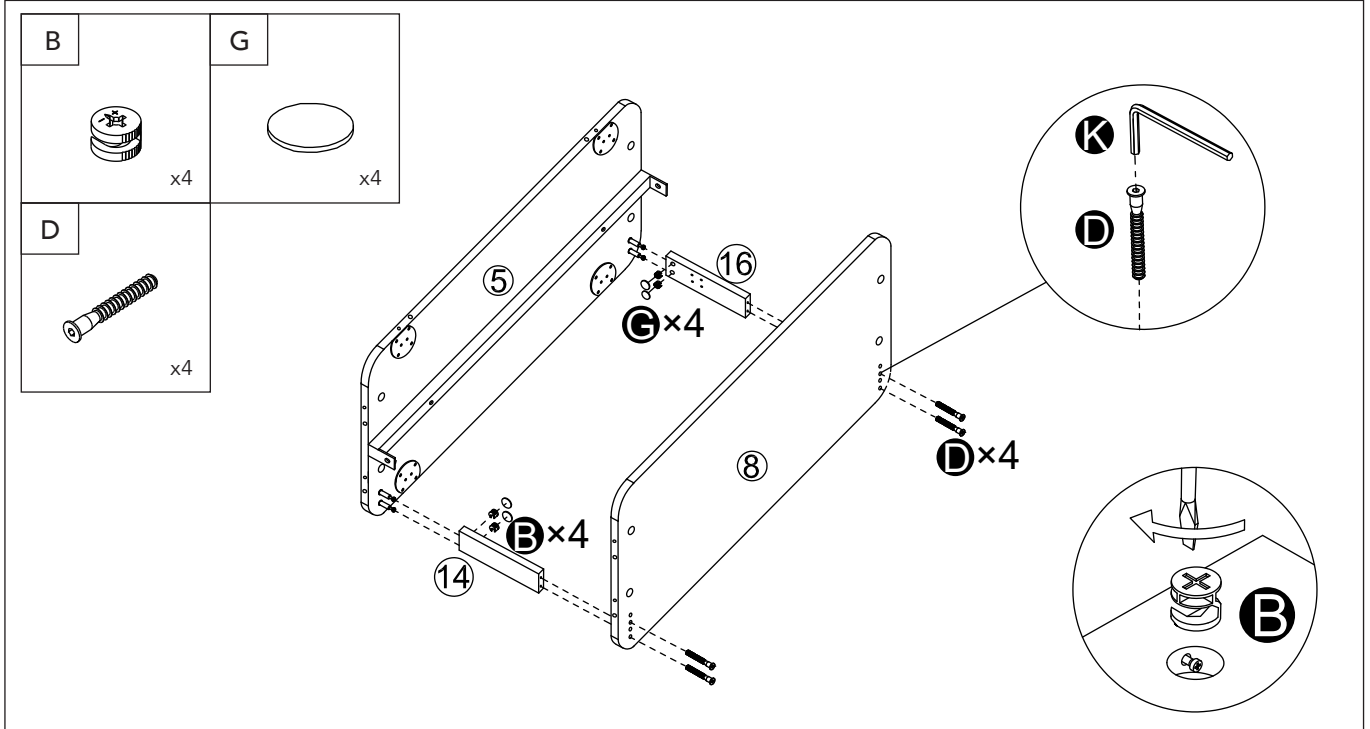

STEP 11

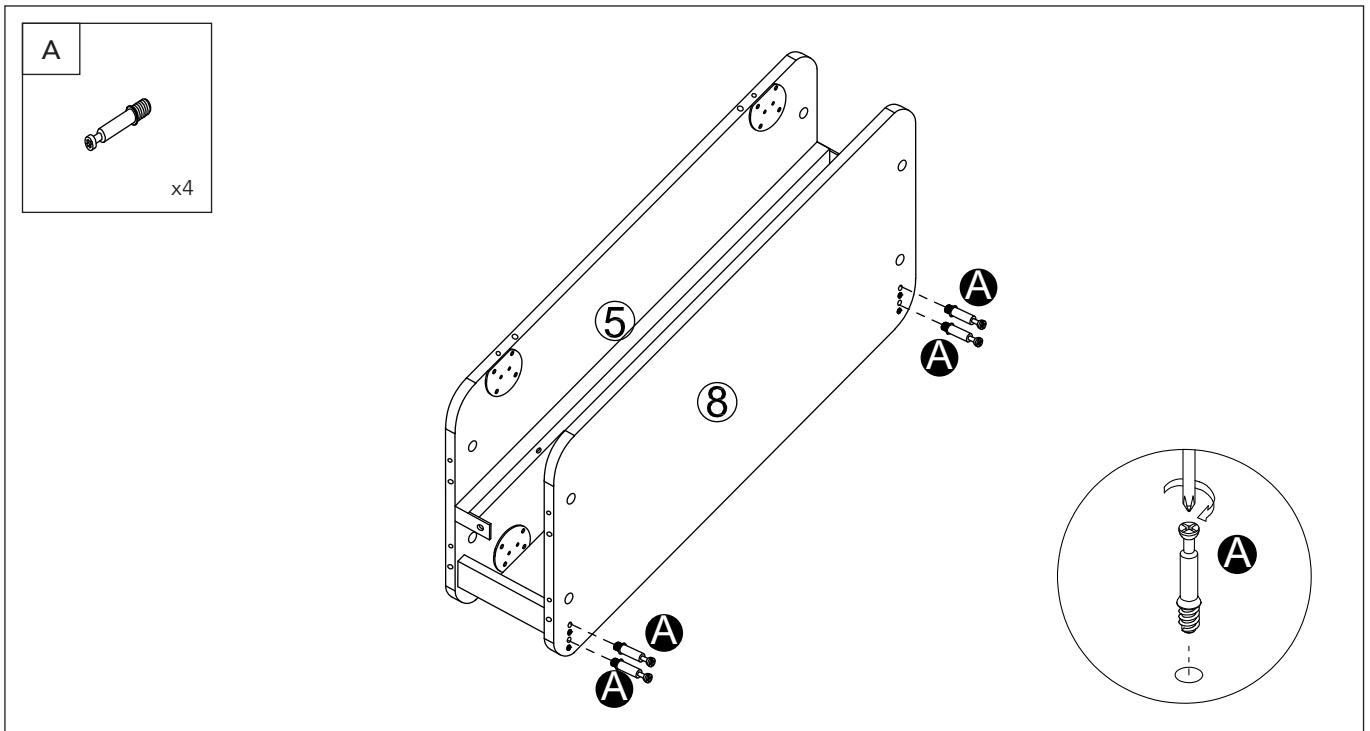

ASSEMBLY INSTRUCTIONS

STEP 12

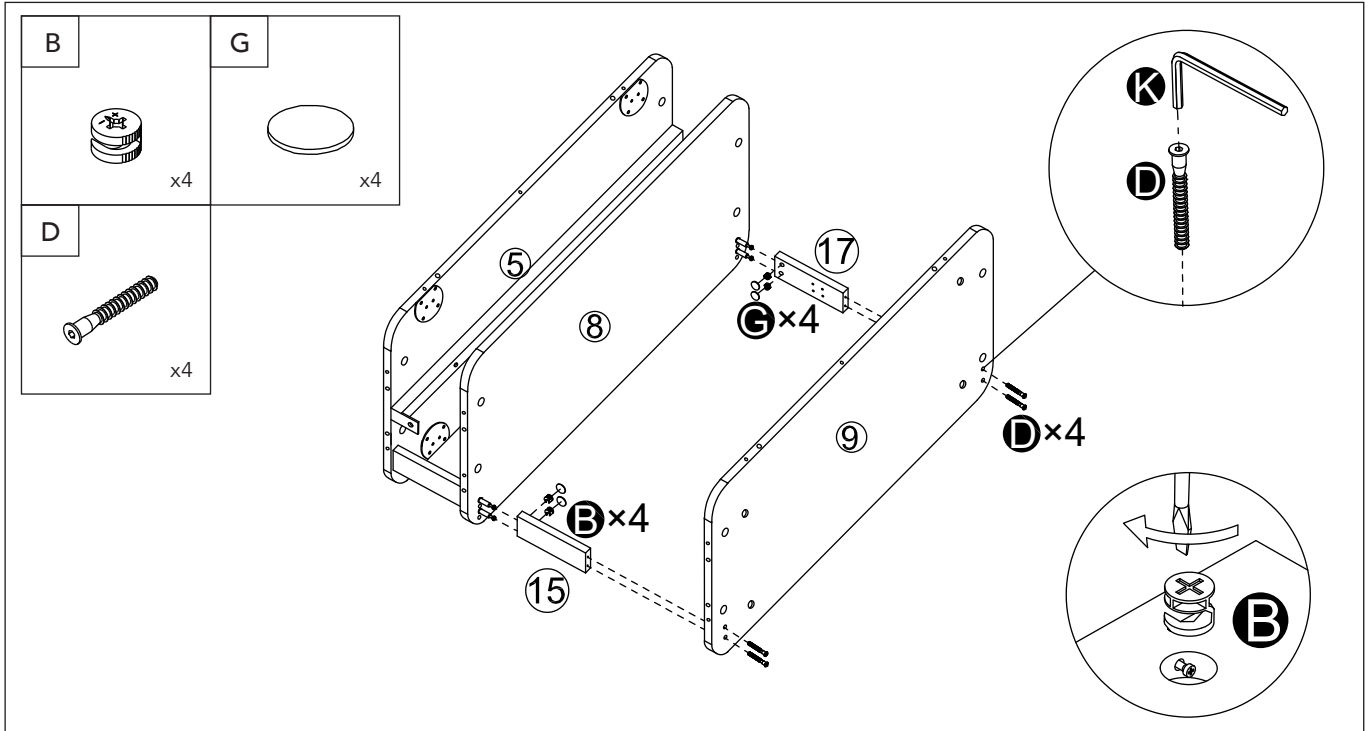

STEP 13

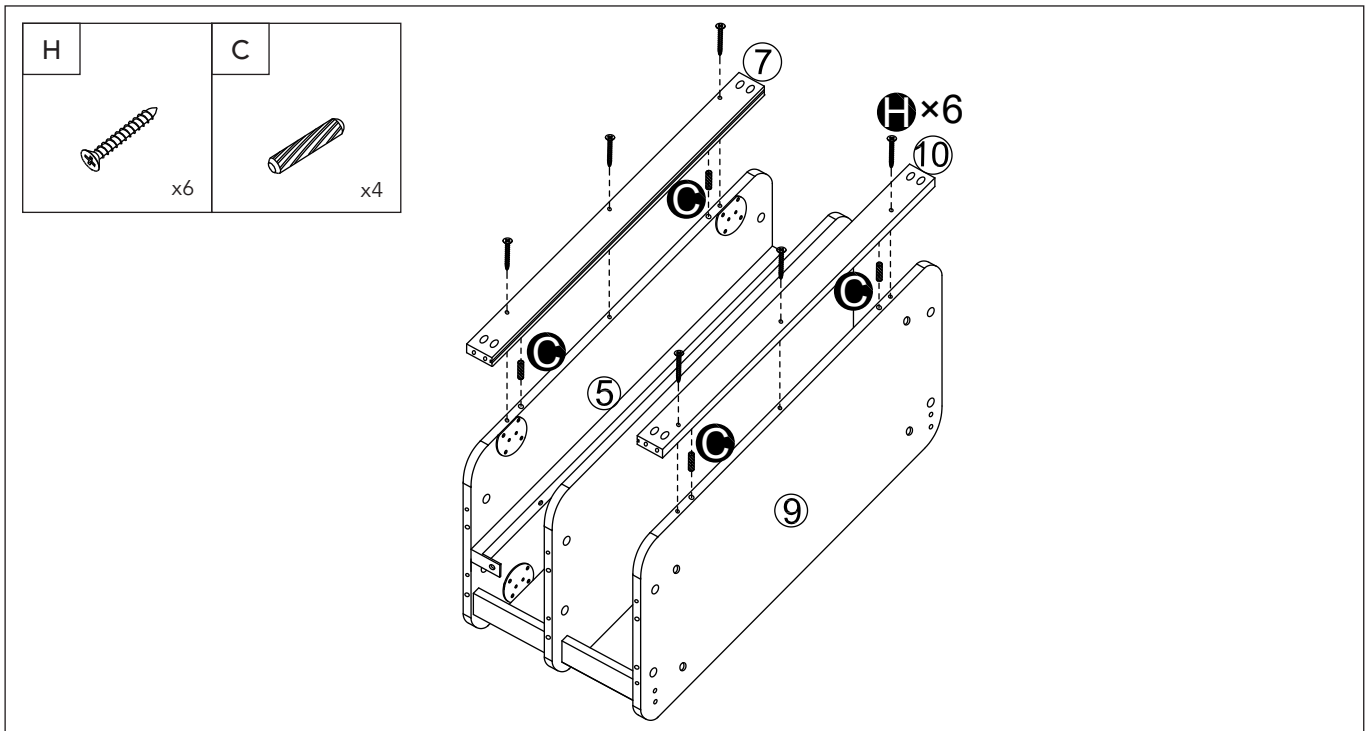

ASSEMBLY INSTRUCTIONS

STEP 14

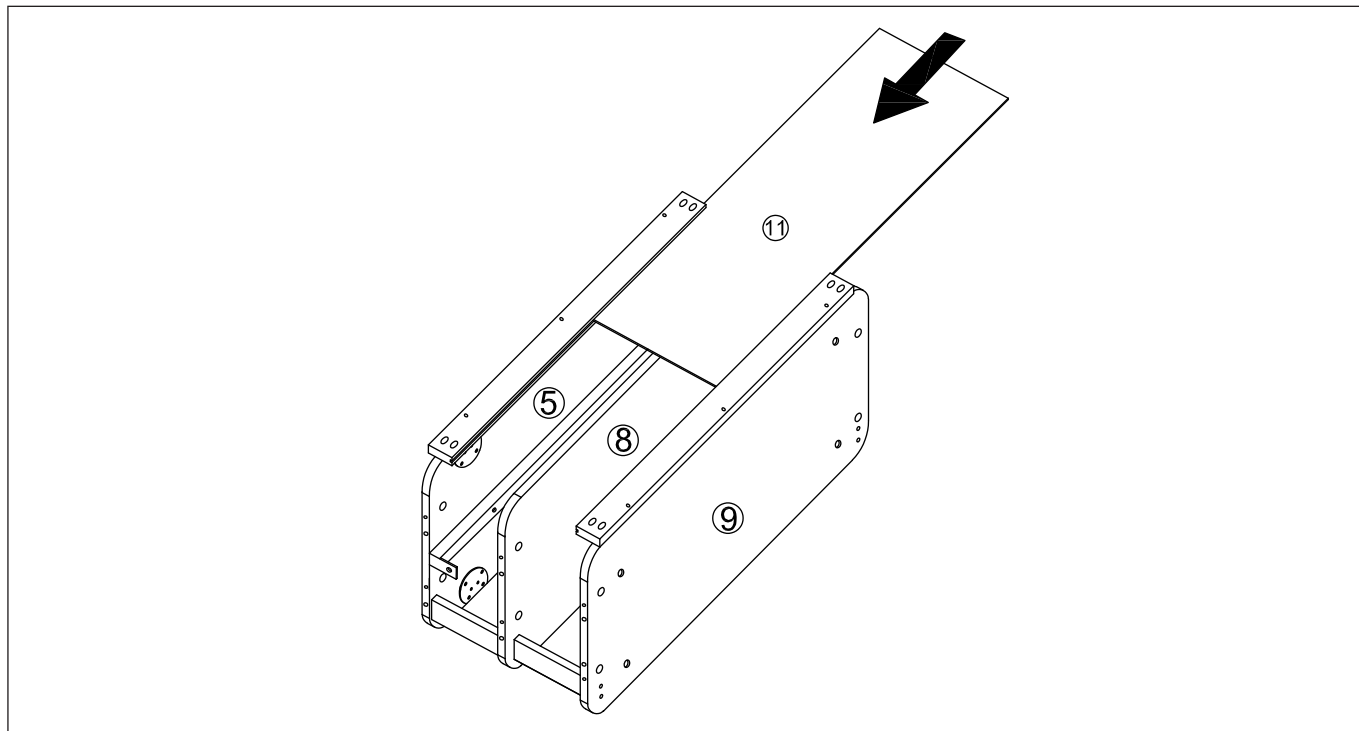

STEP 15

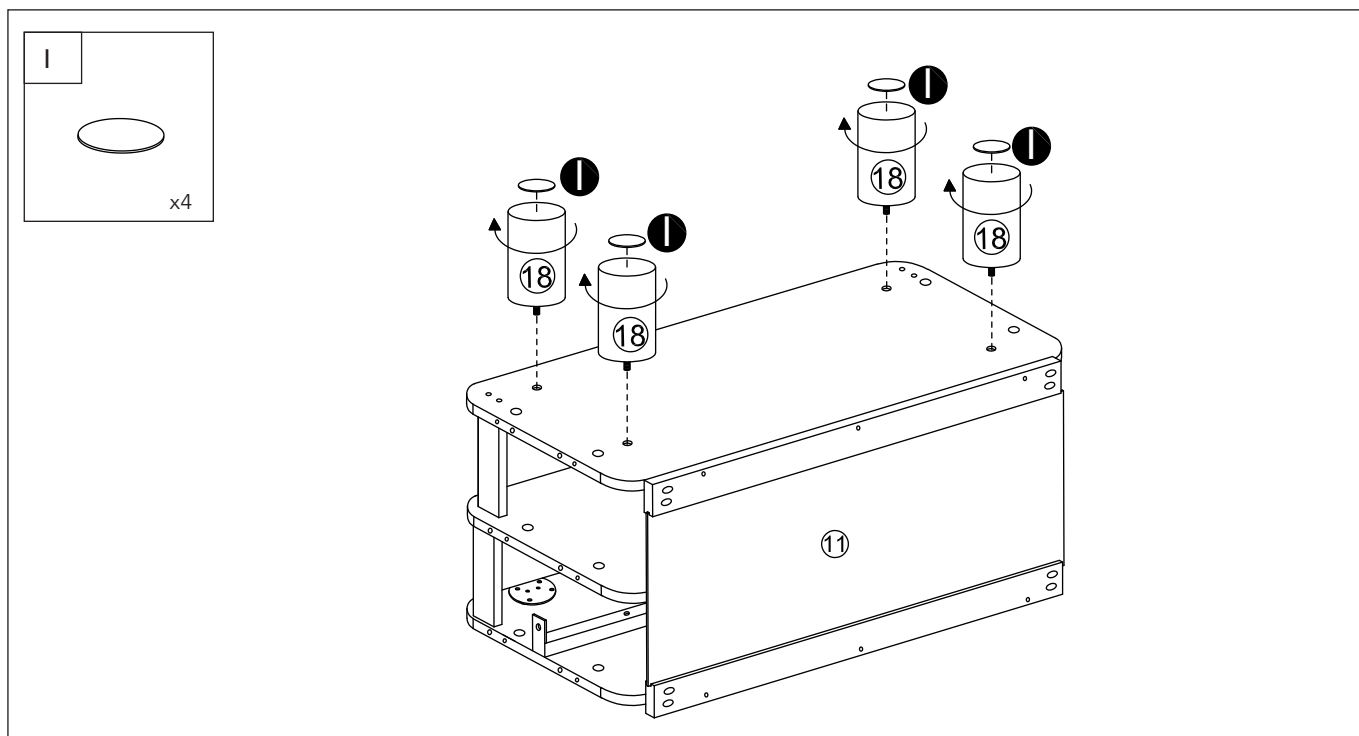

ASSEMBLY INSTRUCTIONS

STEP 16

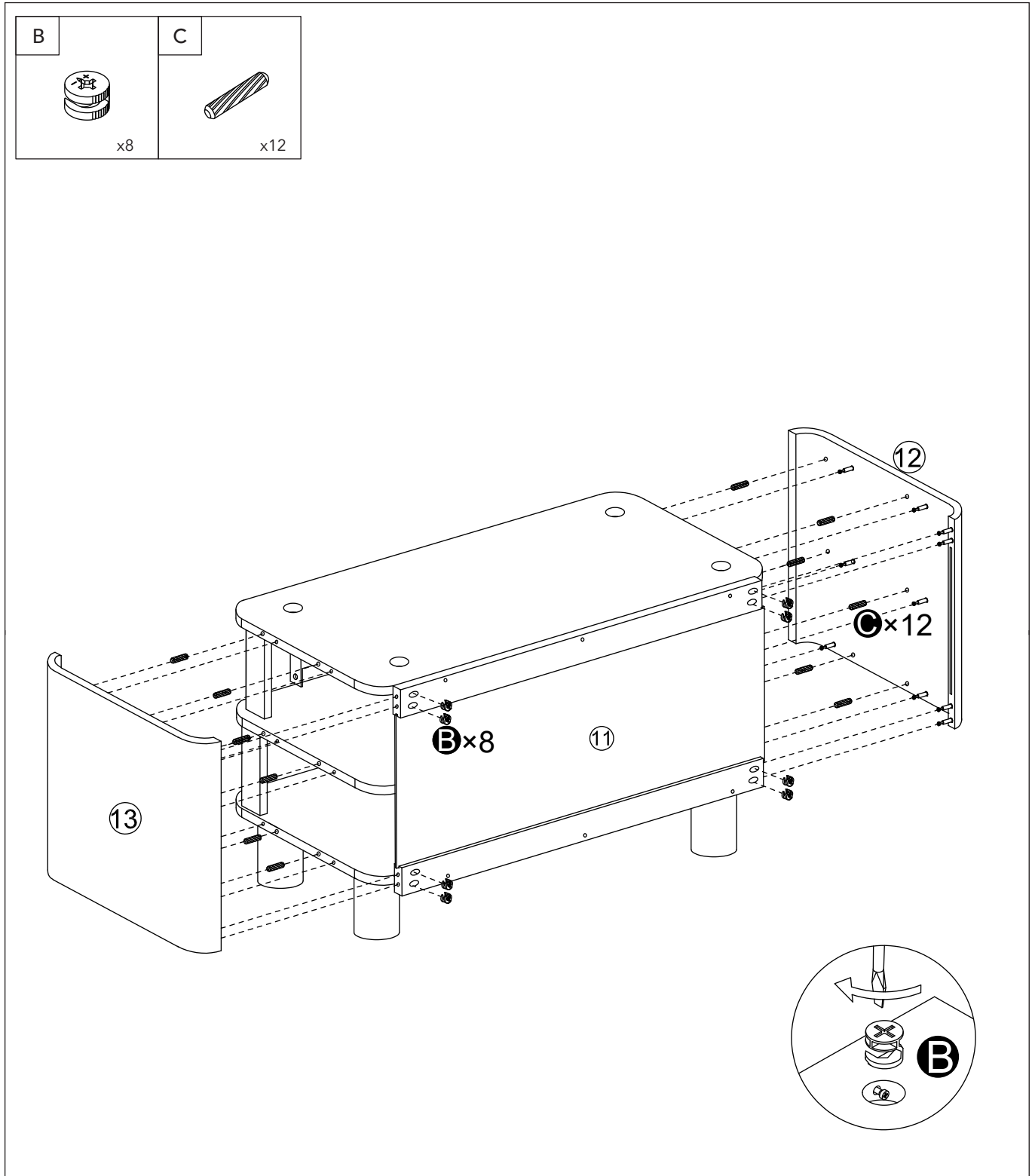

ASSEMBLY INSTRUCTIONS

STEP 17

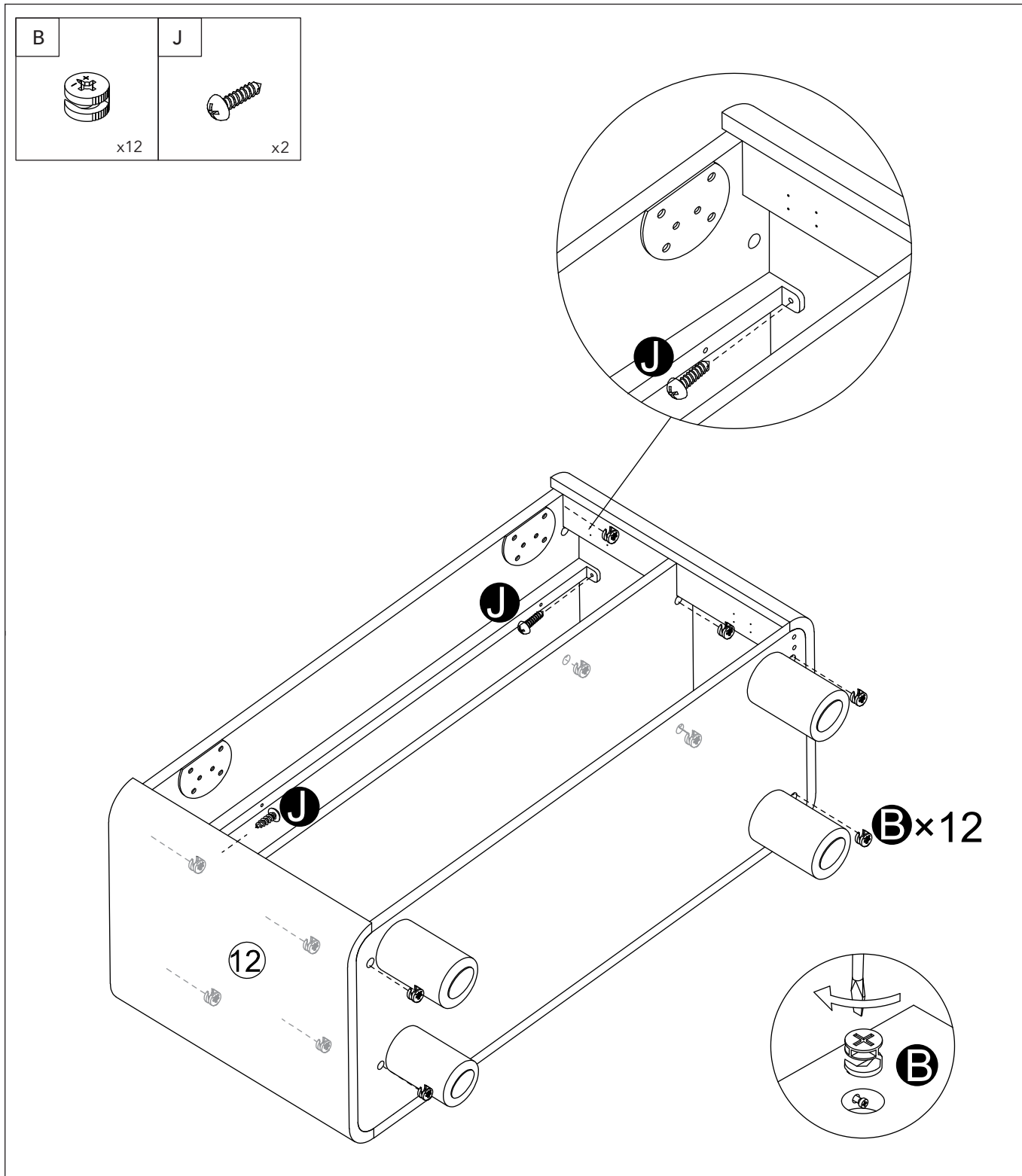

ASSEMBLY INSTRUCTIONS

STEP 18

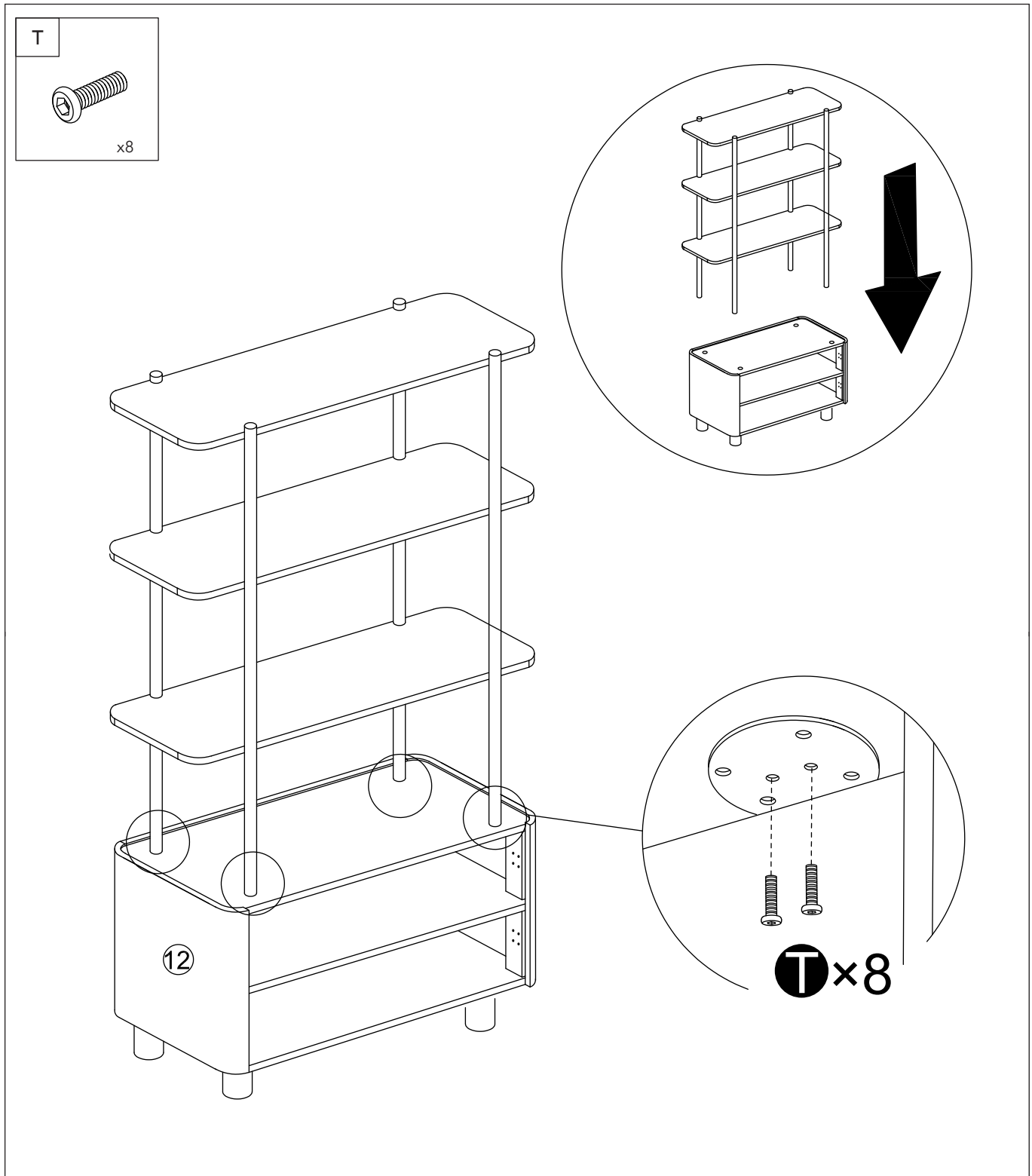

ASSEMBLY INSTRUCTIONS

STEP 19

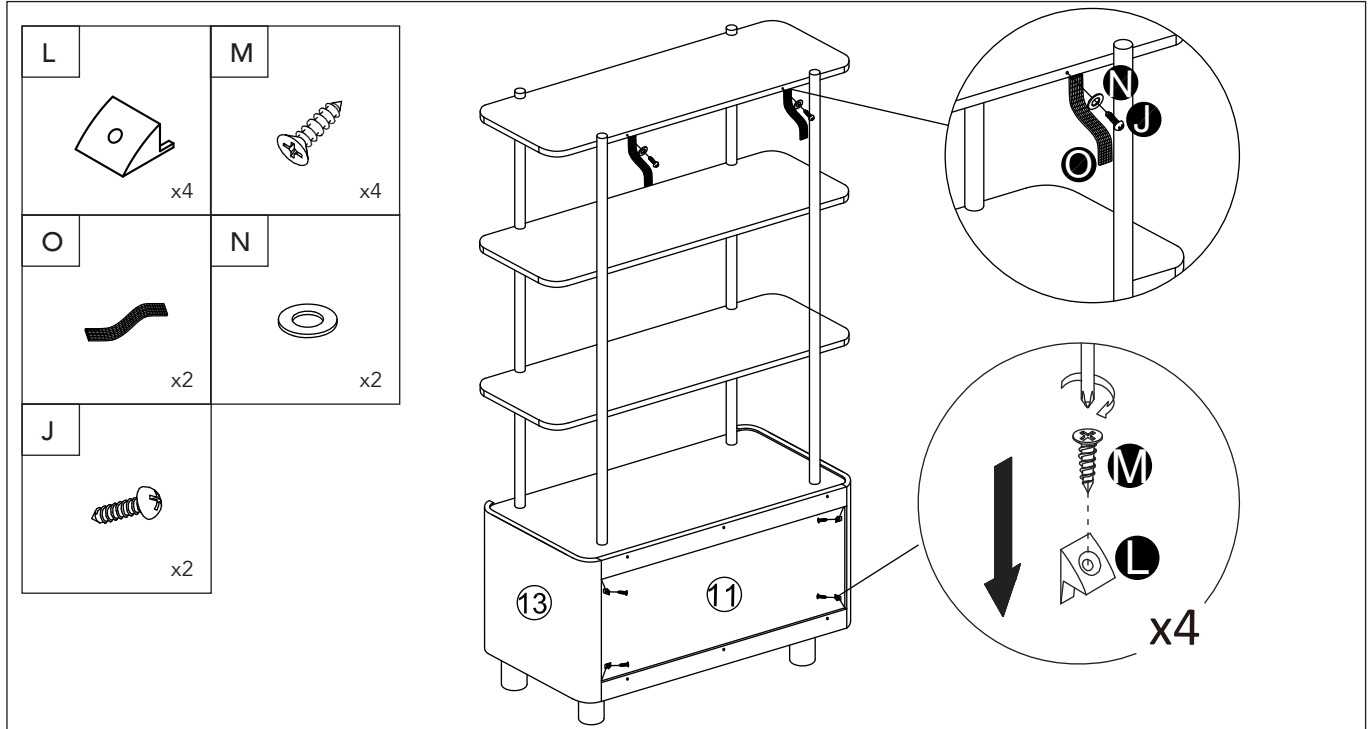

STEP 20

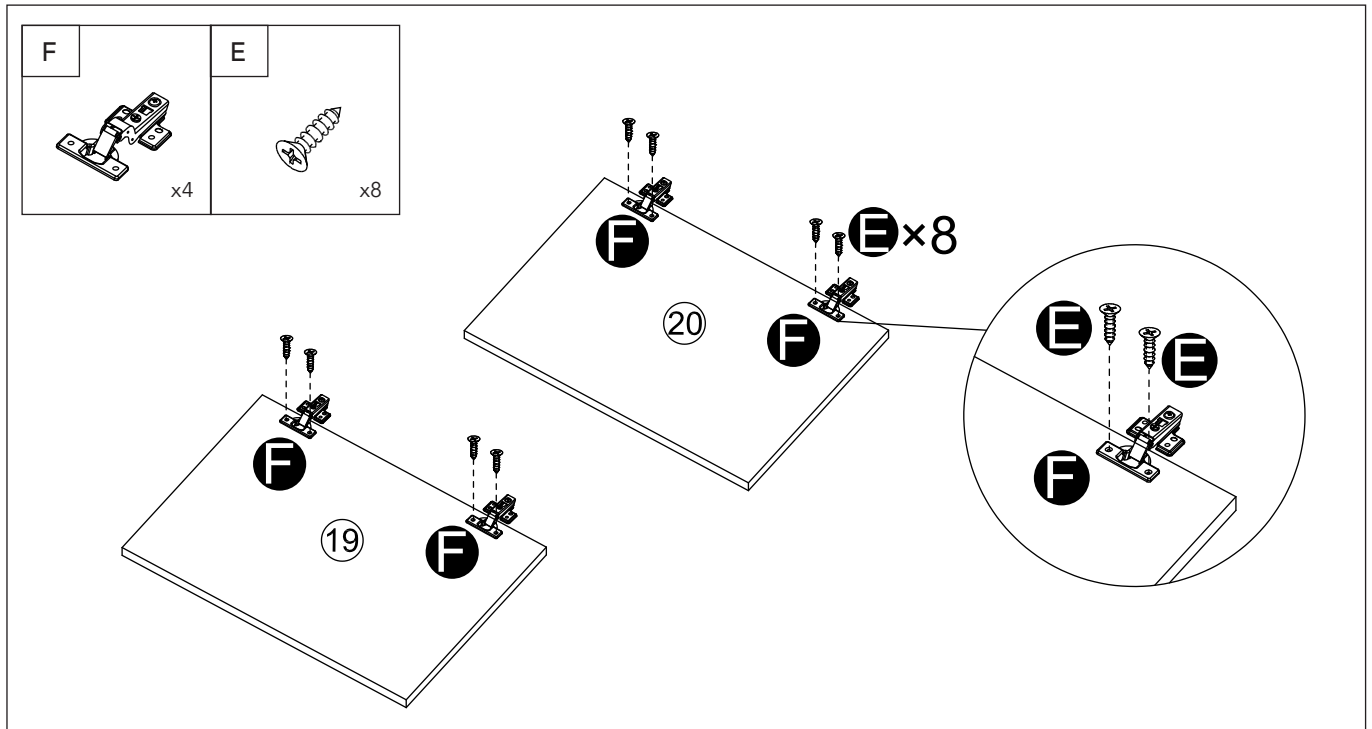

ASSEMBLY INSTRUCTIONS

STEP 21

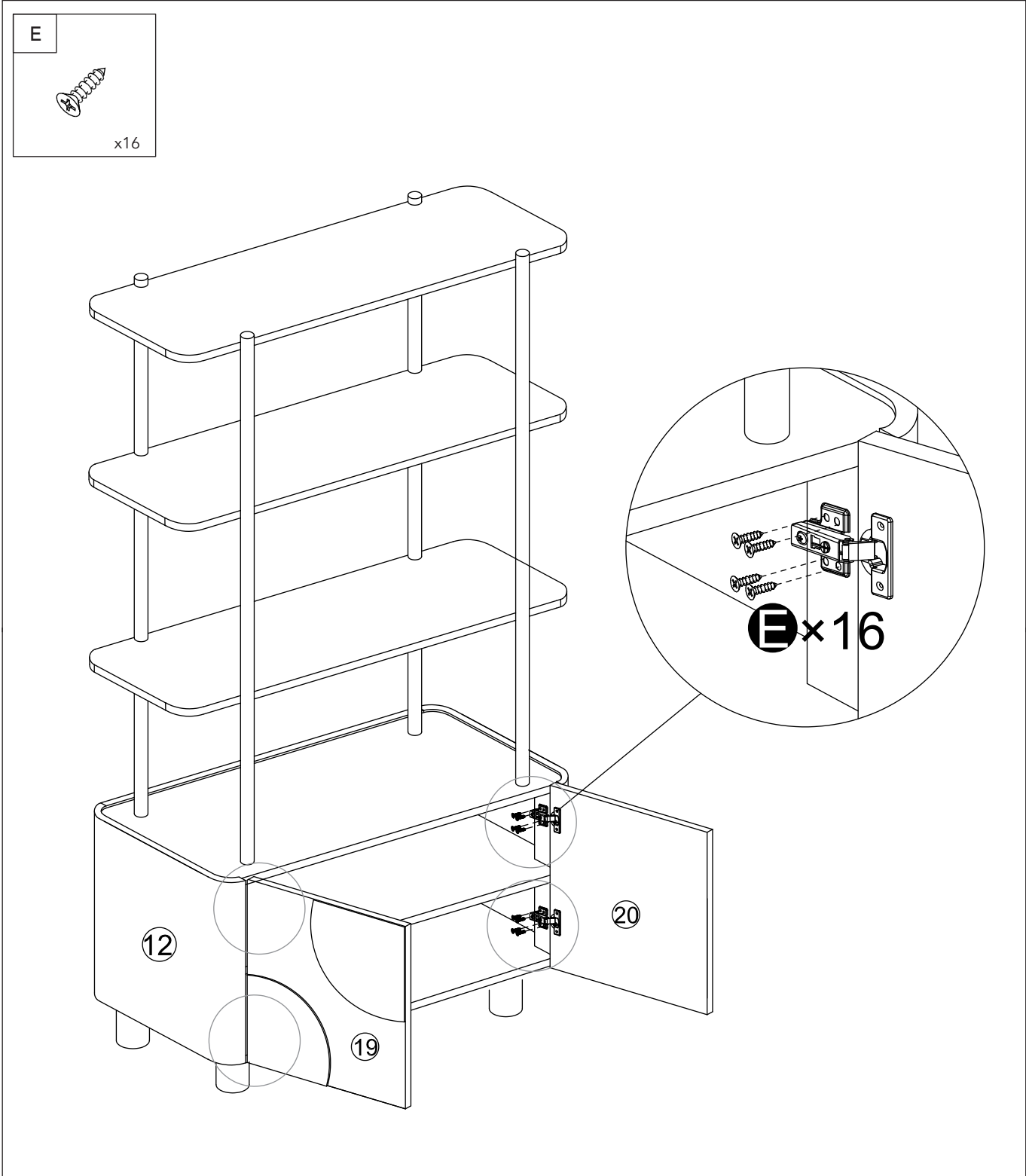

ASSEMBLY INSTRUCTIONS

WALL AFFIXING STEP

PLEASE REFER TO WALL AFFIXING GUIDE INCLUDED IN MANUAL

- For extra stability, you must fix your product to the wall using the additional hardware (H) and (N), as shown.
- Screw (H) is fixed through the bracket (N) and into the wall plug (P).
- Should you choose not to affix the product to the wall, serious injury may be caused if the product tips over.
- Please consider the wall mounting & fixing guide when securing the product.

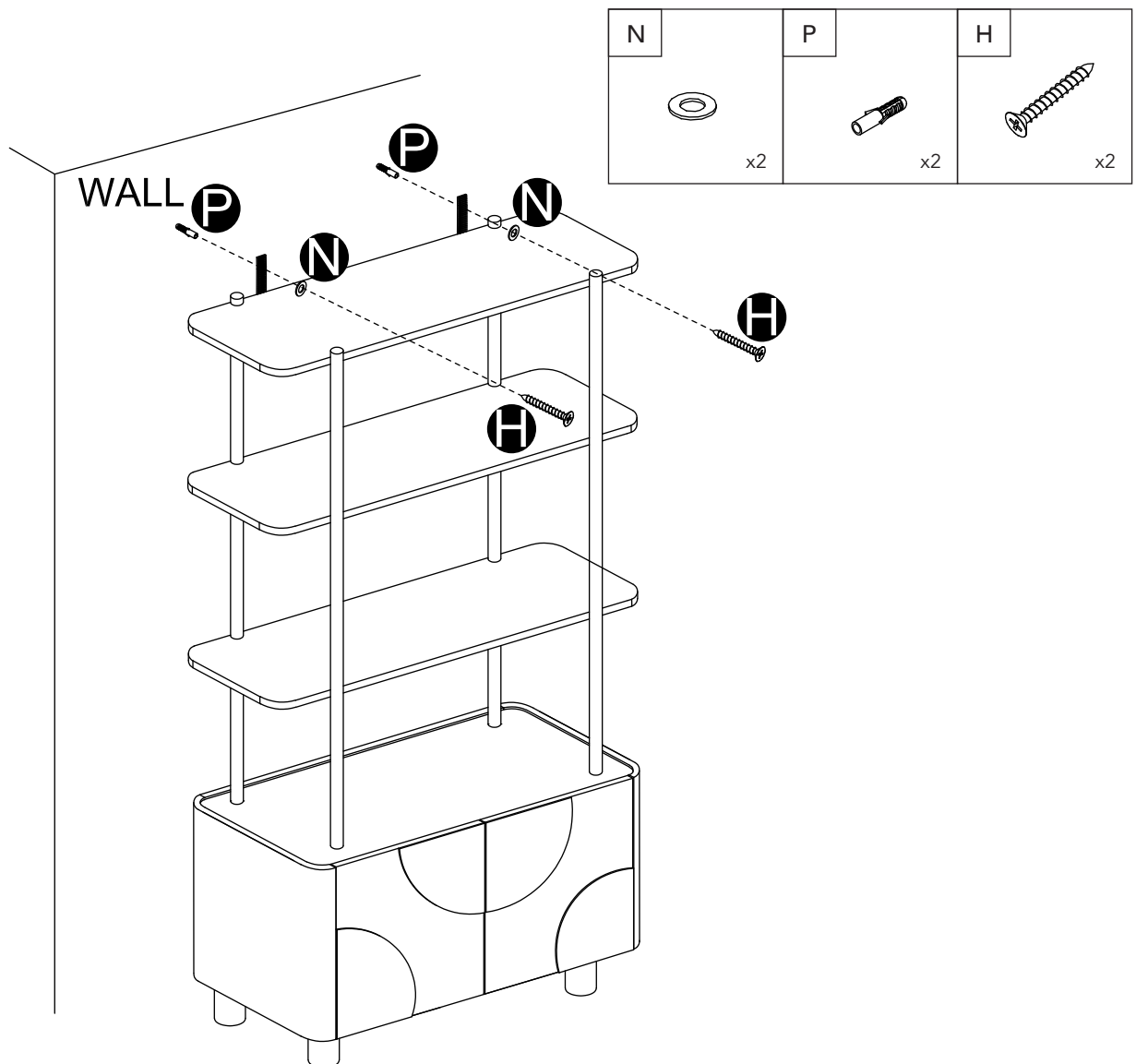

WARNING

Any furniture that is not anchored to a wall has the potential to tip over in certain circumstances, ie. if a child attempts to climb on the furniture or in the event of an earthquake. Accordingly, we recommend that all furniture is anchored to a wall. We supply a free safety wall anchor with all furniture sold and we recommend these are used to prevent your product tipping. The fixing device provided should fit most wall types, but please note that different wall materials may require different fixing devices from those supplied.

ASSEMBLY INSTRUCTIONS

RECOMMENDED WEIGHT

MAXIMUM RECOMMENDED WEIGHT IS 5Kg.

Your new product is ready for use.

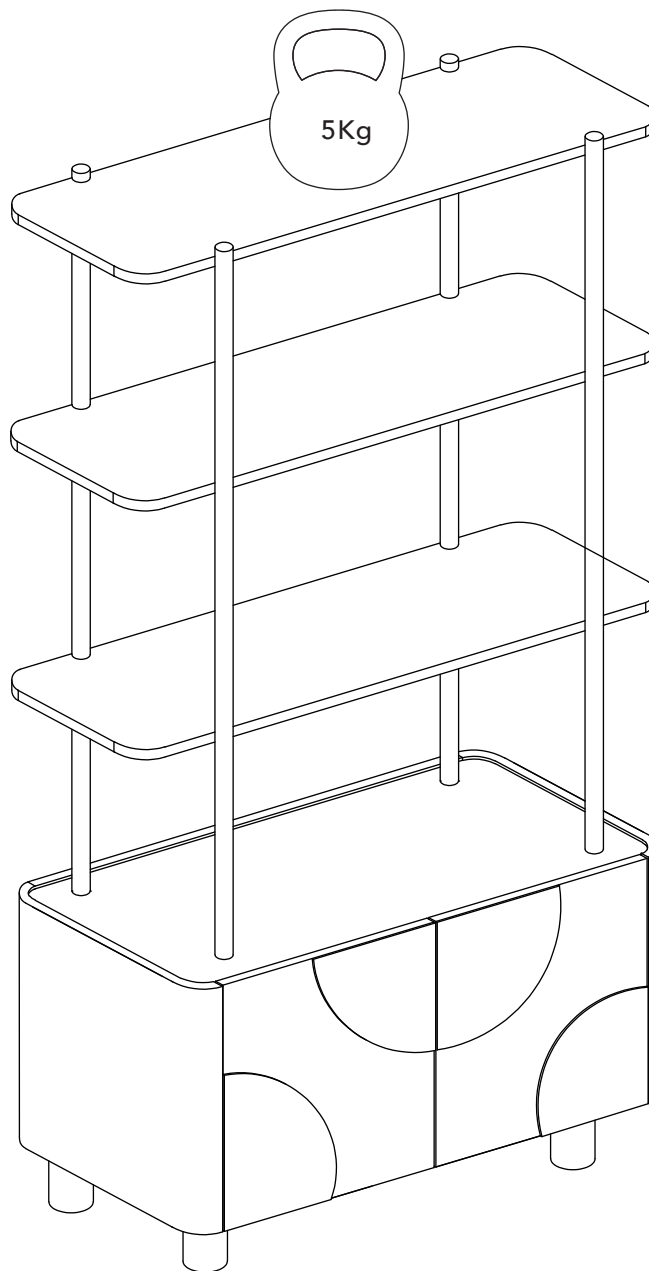

WALL AFFIXING GUIDE

NOTE: Supplied wall plugs are only suitable for use in plasterboard walls.

If you have any doubts about using the correct plug for your wall, please seek professional advice. Failure of the product due to using incorrect fixings is the responsibility of the installer.



IMPORTANT:

When drilling into walls, always check for hidden wires or pipes, etc.



TIPS & TRICKS

Make sure that the hardware used is suitable for supporting your unit. Please consult a qualified tradesperson if unsure.

- Take extra care when drilling high walls, ceiling and ceramic tiles. Ensure wall plugs are inserted beyond the thickness of the ceramic tiles to avoid splitting or cracking.
- If you are unsure, please select a larger screw and wall plug.
- Ensure that you use the recommended drill bit to match the wall plug and hole size.
- Ensure that wall plugs are well fitted and are a tight fit in the drilled hole.

TYPES OF WALLS

Use one of the following types of wall plug (not included) if your walls are made of brick, breeze block, concrete, stone or wood. Screws may be able to be fixed directly to solid wood walls as they will provide a secure anchor point.

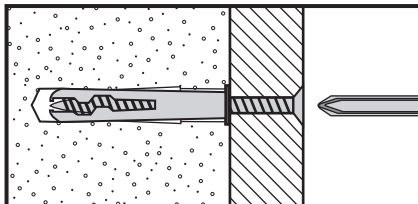

GENERAL PURPOSE WALL PLUG

Generally, aerated blocks should not be used to support heavy loads, use a specialist fitting in this case. For light loads, general purpose wall plugs can be used.

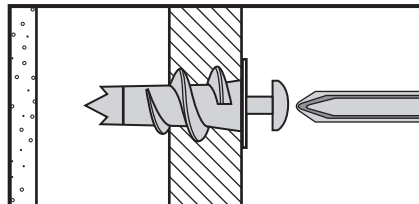

PLASTERBOARD WALL PLUG

For use when attaching light loads onto plasterboard partitions.

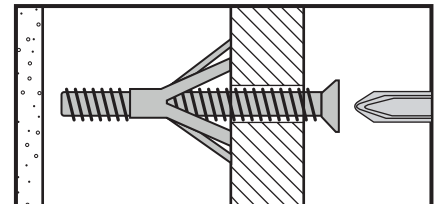

CAVITY FIXING WALL PLUG

For use with plasterboard partitions or hollow wooden doors.

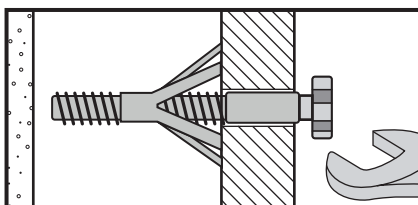

CAVITY FIXING HEAVY DUTY WALL PLUG

For use when fitting or supporting heavy loads such as shelving and wall cabinets.

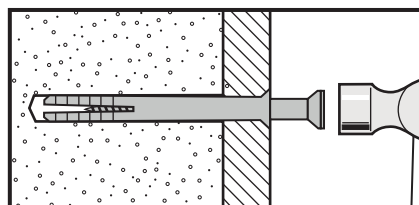

HAMMER FIXING WALL PLUG

For use with concrete block or brick walls, or walls stuck with plasterboard. The hammer fixing allows it to be fixed to the wall rather than the plasterboard. Always check the fixing is secure to the retaining wall.

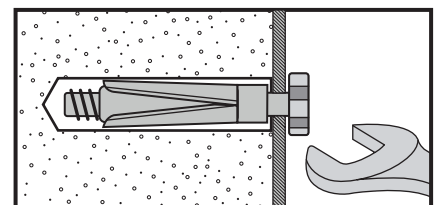

SHIELD ANCHOR WALL PLUG HEAVY LOADS

For use with concrete or brick walls, or for use with heavier loads such as TV & HiFi speakers and satellite dishes, etc.

HINGE ADJUSTMENT GUIDE

STEP 1
Open the door.

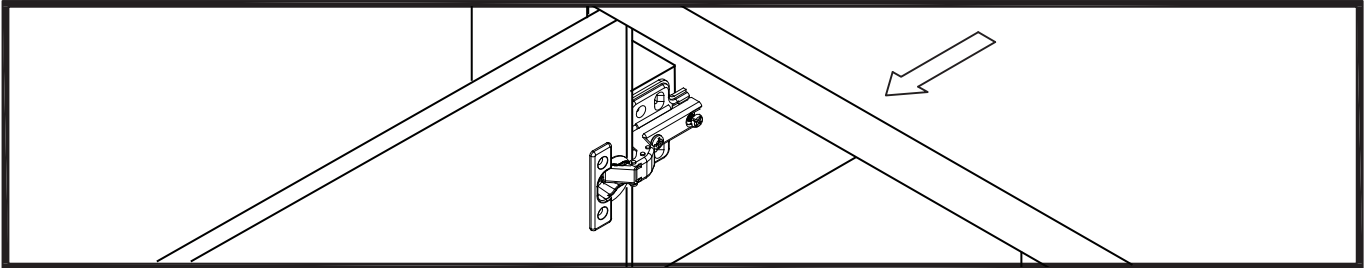

STEP 2
Adjust the door move in or out a little.

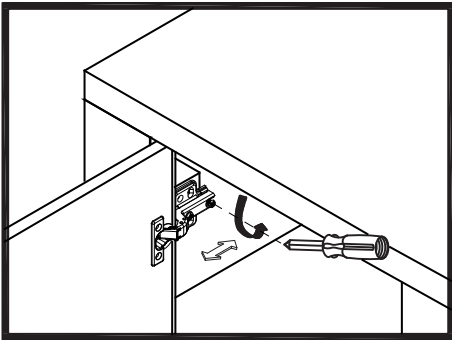

Loosen the screw indicated a little, adjust the hinge to right position (see Step 2A & 2B), then tighten screw.

STEP 2A
Move door in.

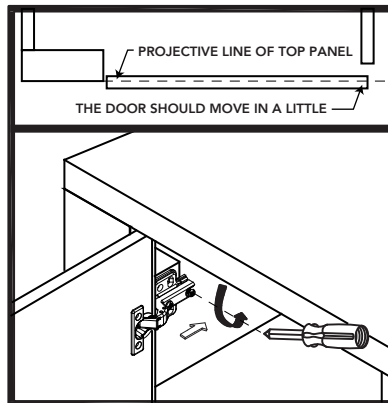

Push the hinge back a little.

STEP 2B
Move door out.

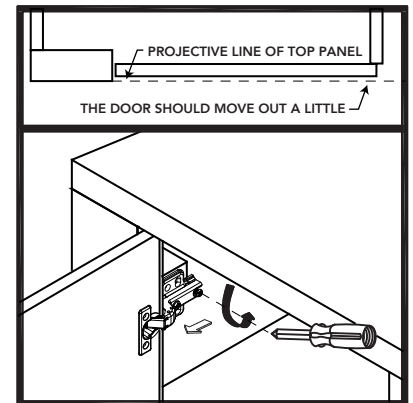

Push the hinge forward a little.

STEP 3
To adjust the gap between door & leg.

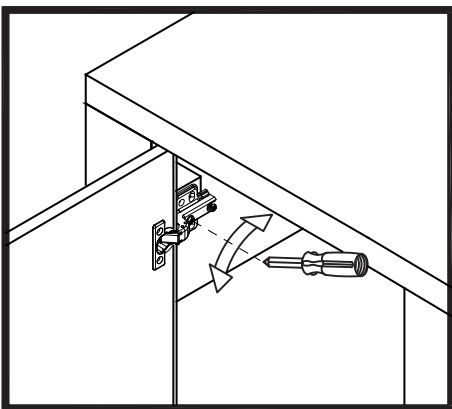

Loosen or tighten the screw indicated a little to adjust the gap between door and leg (see Step 3A & 3B).

STEP 3A
Move door right.

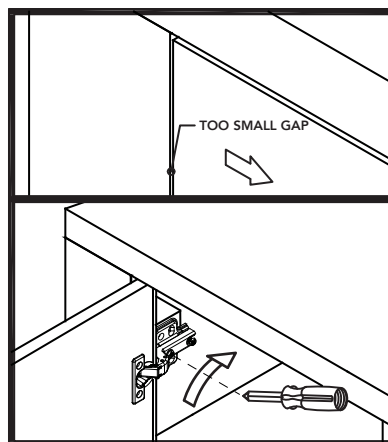

Turn the screw clockwise a little as shown to make the gap big.

STEP 3B
Move door left.

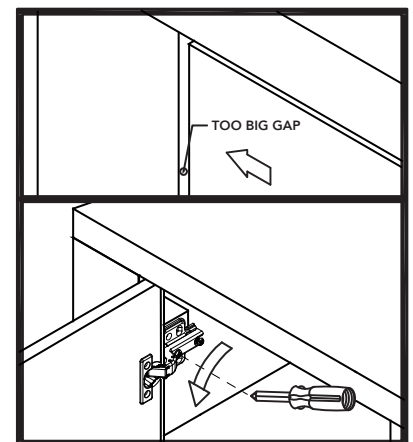

Turn the screw counterclockwise a little as shown to make the gap small.

CARE & MAINTENANCE OF YOUR PRODUCT

Just a few simple steps to keep your furniture looking fabulous and functioning flawlessly:

- Please periodically check all fittings and re-tighten as necessary.
- To clean your item, please use a damp cloth and wipe clean.
- To clean glass, please use glass cleaner.
- Never allow any kind of liquid to remain on your furniture.
Absorption can cause wood to warp or finishes to de-laminate.
- Please do not place hot items (eg. hot drinks) directly on to the surface.
- Please do not drag and pull your furniture.

WARRANTY

Cooper & Co products are warranted to be free from defects in materials and workmanship for the warranty period of 12 months from the date of retail sale. Our goods come with guarantees that cannot be excluded under the Australian Consumer Law. You are entitled to a replacement or refund for a major failure and for compensation for any other reasonably foreseeable loss or damage. You are also entitled to have the goods repaired or replaced if the goods fail to be of acceptable quality and the failure does not amount to a major failure.

Cooper & Co.[®]

Cooper & Co products are waiting for you at:

www.cooperandco.com.au

Find us on Instagram at:

[cooperandco_australia](https://www.instagram.com/cooperandco_australia)

WARNING

WARNING

Children have died from furniture toppling over

- ALWAYS secure this furniture with an anchor device.
- NEVER allow children to stand, climb or hang on drawers, doors or shelves.
- NEVER open more than one drawer at a time.
- NEVER place televisions on this item.
- ALWAYS place heavy items low down

