

Cooper & Co.[®]

Bobble Toy Storage Box

ASSEMBLY
INSTRUCTIONS

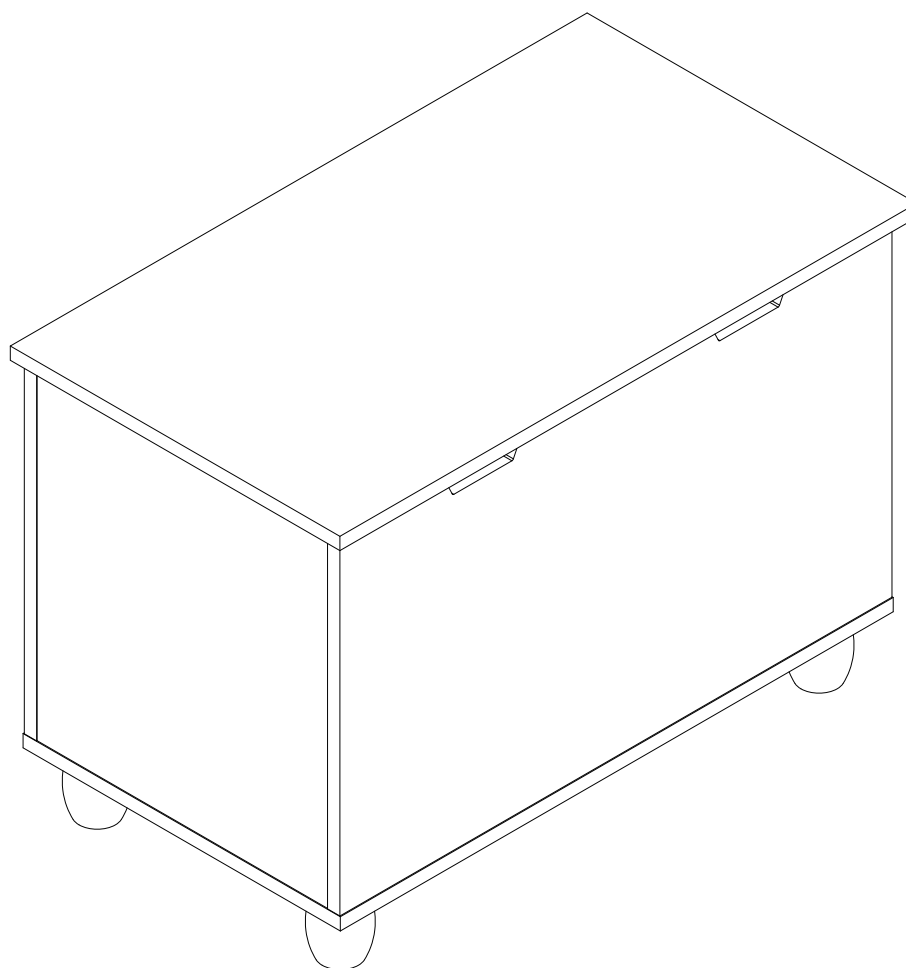

Cooper & Co.[®]

Cheers for making this yours!

Cooper & Co is your go-to source for homeware that's as stylish as it is affordable! With our carefully curated selection, we aim to bring you the best of both worlds, ensuring that you can create a space that reflects your personal style without breaking the bank.

We're on a mission to sprinkle some pizzazz into every home. Whether you're looking to transform your living room, kitchen, or bedroom into a masterpiece, fret not! With us, you don't have to sacrifice quality or design.

TIPS BEFORE YOU START

1. Sit back, take a deep breath, and get ready to dive into the laid-back world of furniture assembly. We've got your back with some simple instructions that will have you relaxing with your amazing new piece in no time.
2. Please check that all parts are present before you start the assembly of your furniture.
3. For ease and speed of assembly, we recommend that before you commence each step of the assembly, that you identify all the parts required for that step.
4. For larger items, please ensure that you have sufficient space and people to assemble your product safely.
5. We recommend that, where possible, all items are assembled near to the area in which they will be placed in use, to avoid moving the product unnecessarily once assembled.
6. For the protection of your furniture, we recommend that the product is placed on a protected surface during assembly to prevent any damage.
7. During assembly please take care not to over-tighten any fittings, as this may damage the product. Do not use power tools.
8. Always place the product on a flat, steady and stable surface.
9. Do not stand on the product. Do not use the product as a stepladder.
10. This product is intended for indoor, household use only as it is a non-industrial product.
11. Please use caution and care when lifting the product to avoid personal injury and/or product damage.

ASSEMBLY REQUIREMENTS

- 1.5m x 1.5m assembly space required. Give your furniture some breathing room!
- Approximately 1.5 hour assembly time. Remember, it's not a race, so take your time, enjoy the process.
- 1 x adult required, enlist the help of your favourite tag team.



USING CAM LOCK & QUICKFIT

QUICKFIT

Tighten quickfit until shoulder is flush with panel. Do not overtighten or undertighten.

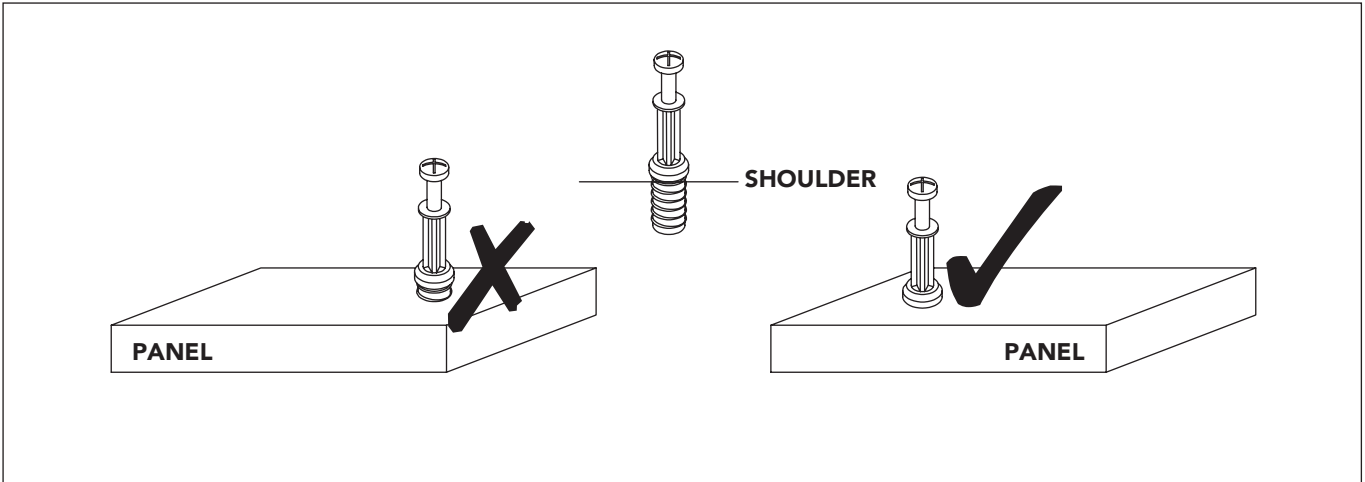

CAM LOCK

When fitting cam lock, ensure starting position is correct before you insert connecting quickfit.

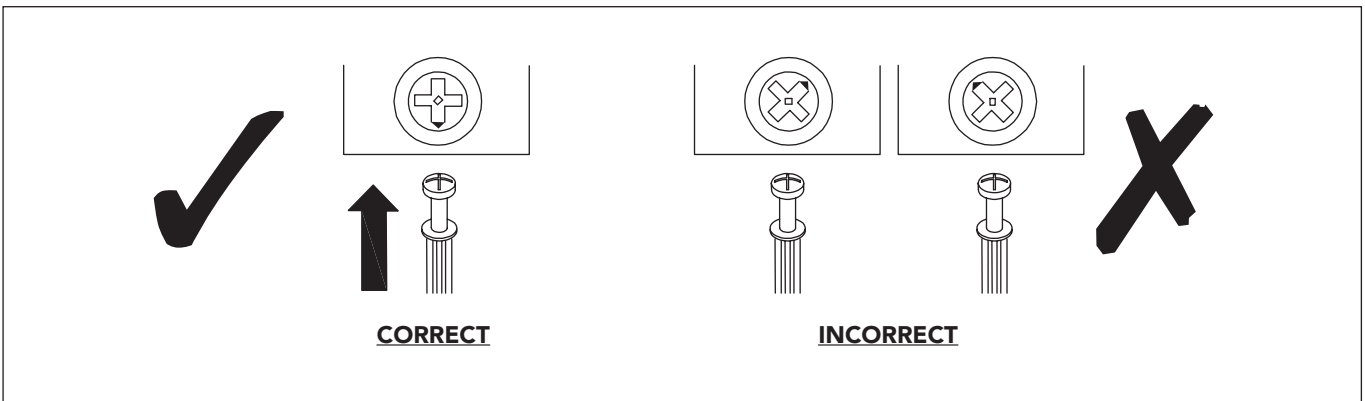

Quickfit head should be in the centre of the cam lock when the two panels are joined. Cam lock should be inserted before quickfit.

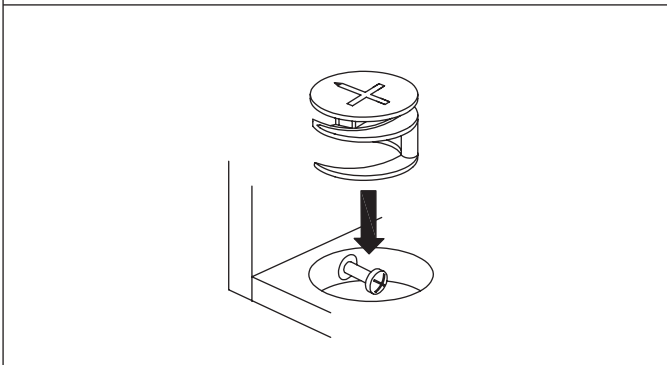

Turn cam lock clockwise to tighten.

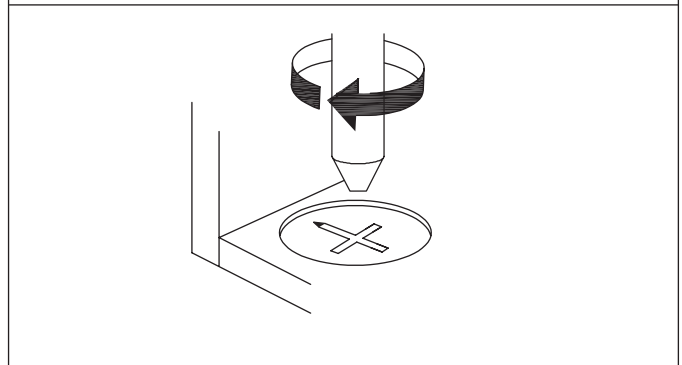

PARTS LIST

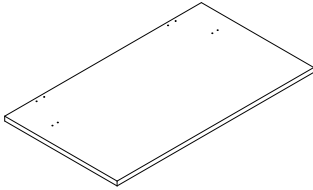
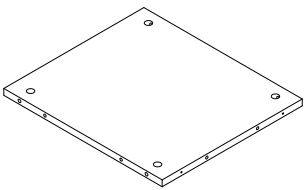
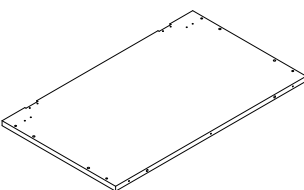
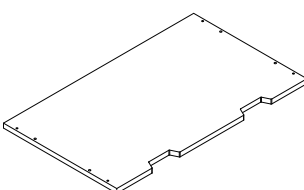
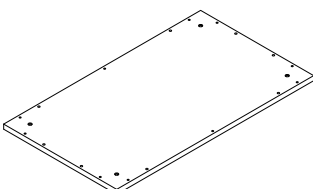
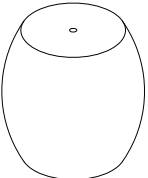
<p>1</p>  <p>x1</p>	<p>2</p>  <p>x2</p>	<p>3</p>  <p>x1</p>	<p>4</p>  <p>x1</p>
<p>5</p>  <p>x1</p>	<p>6</p>  <p>x4</p>		

HARDWARE

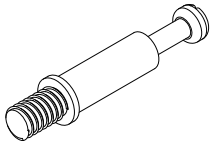
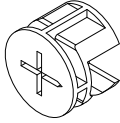
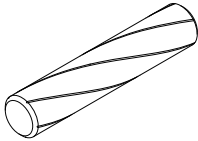
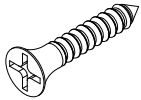
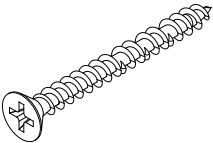
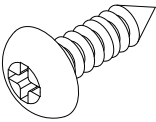
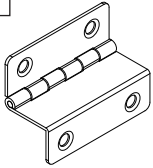
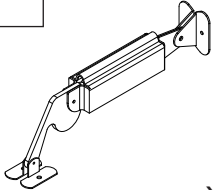
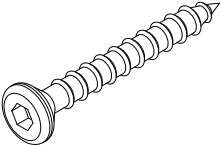
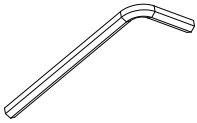
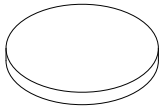
<p>A</p>  <p>x8</p>	<p>B</p>  <p>x8</p>	<p>C</p>  <p>x16</p>	<p>D</p>  <p>x8</p>
<p>E</p>  <p>x10</p>	<p>F</p>  <p>x8</p>	<p>G</p>  <p>x2</p>	<p>H</p>  <p>x2</p>
<p>I</p>  <p>x4</p>	<p>J</p>  <p>x1</p>	<p>K</p>  <p>x4</p>	

ASSEMBLY INSTRUCTIONS

STEP 1

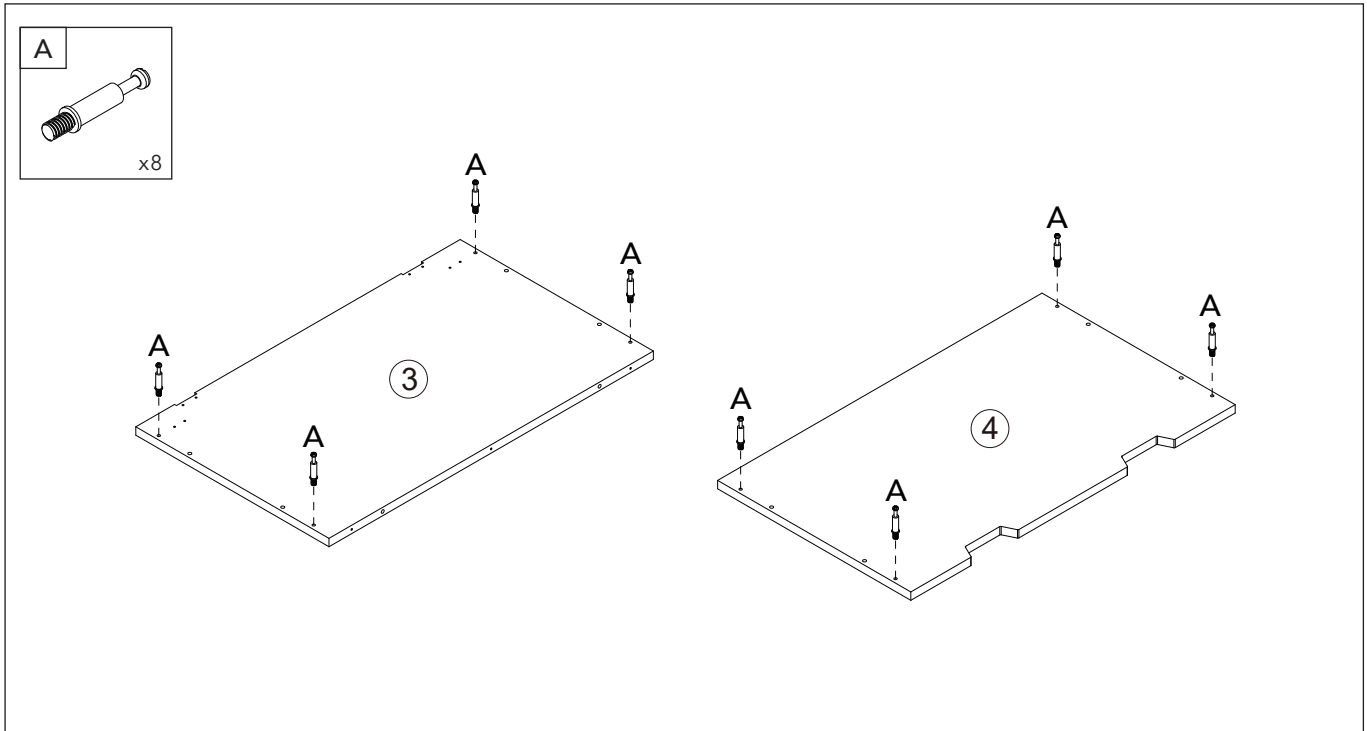

STEP 2

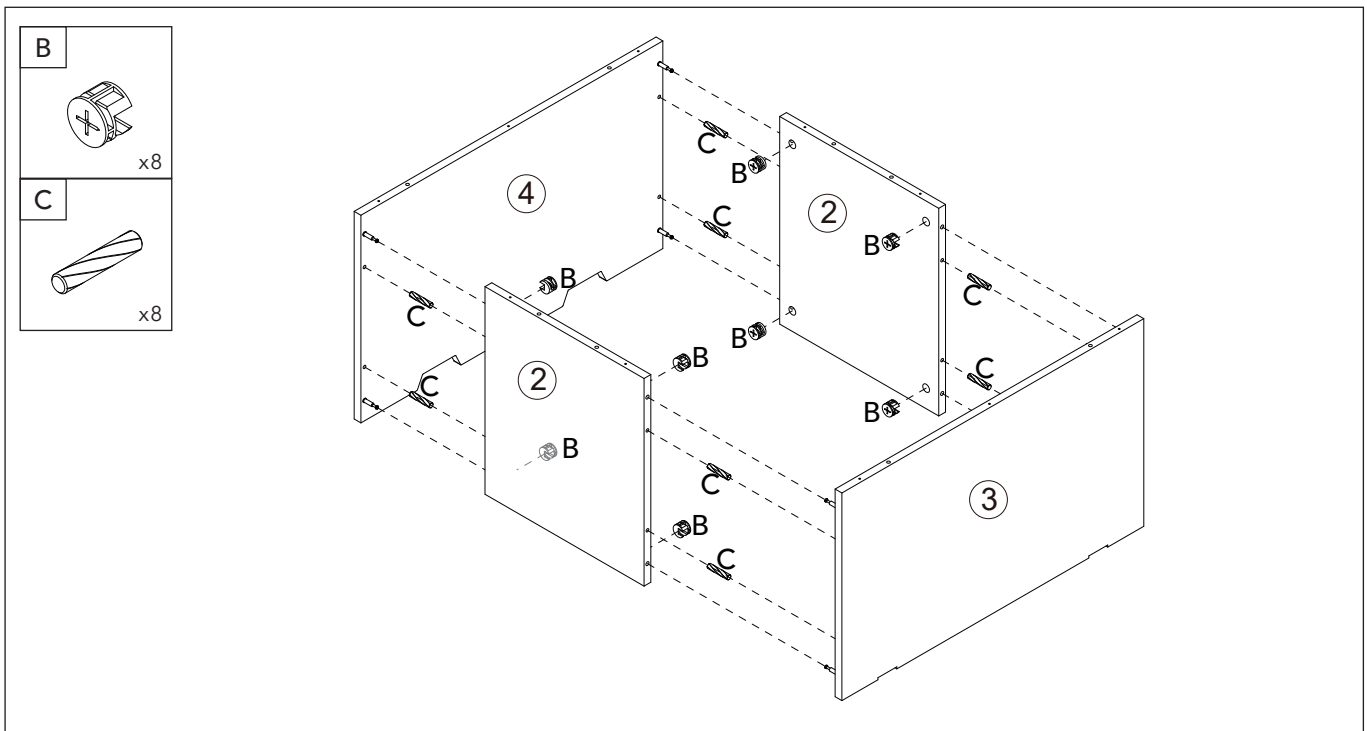

ASSEMBLY INSTRUCTIONS

STEP 3

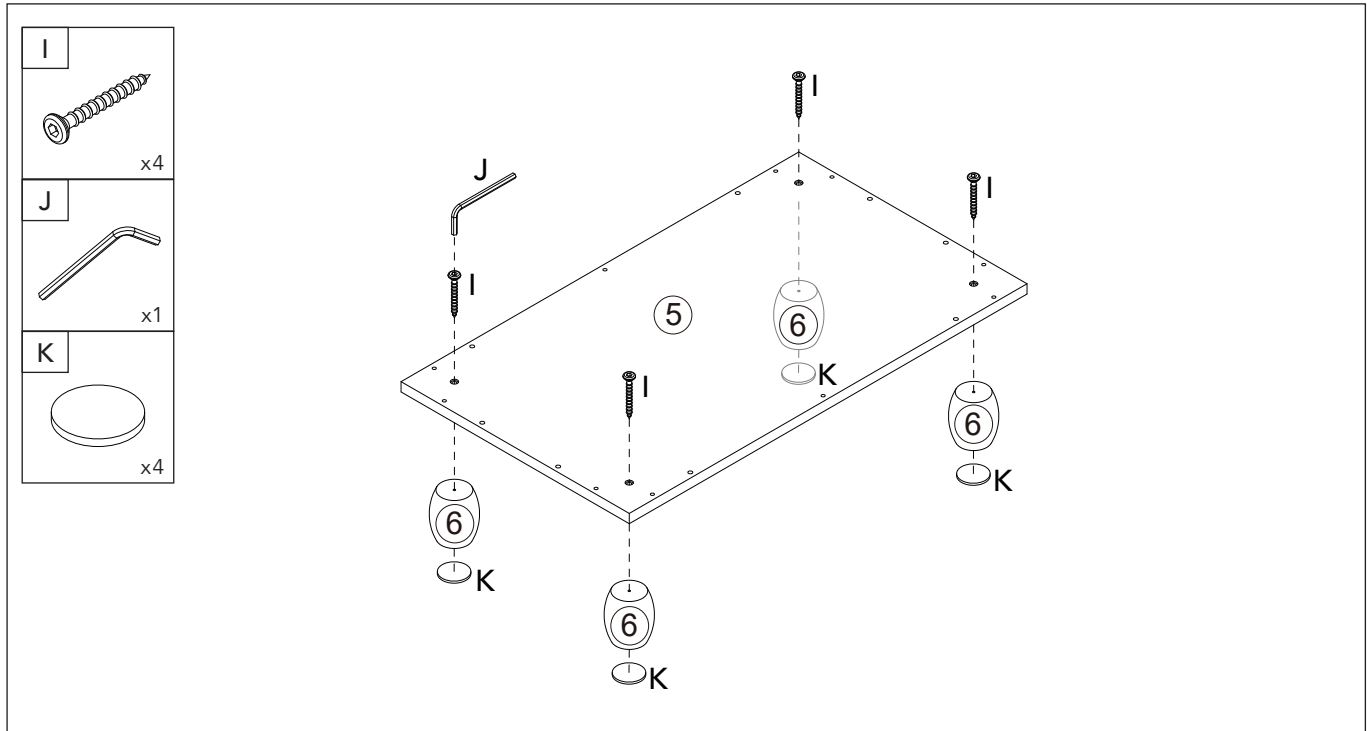

STEP 4

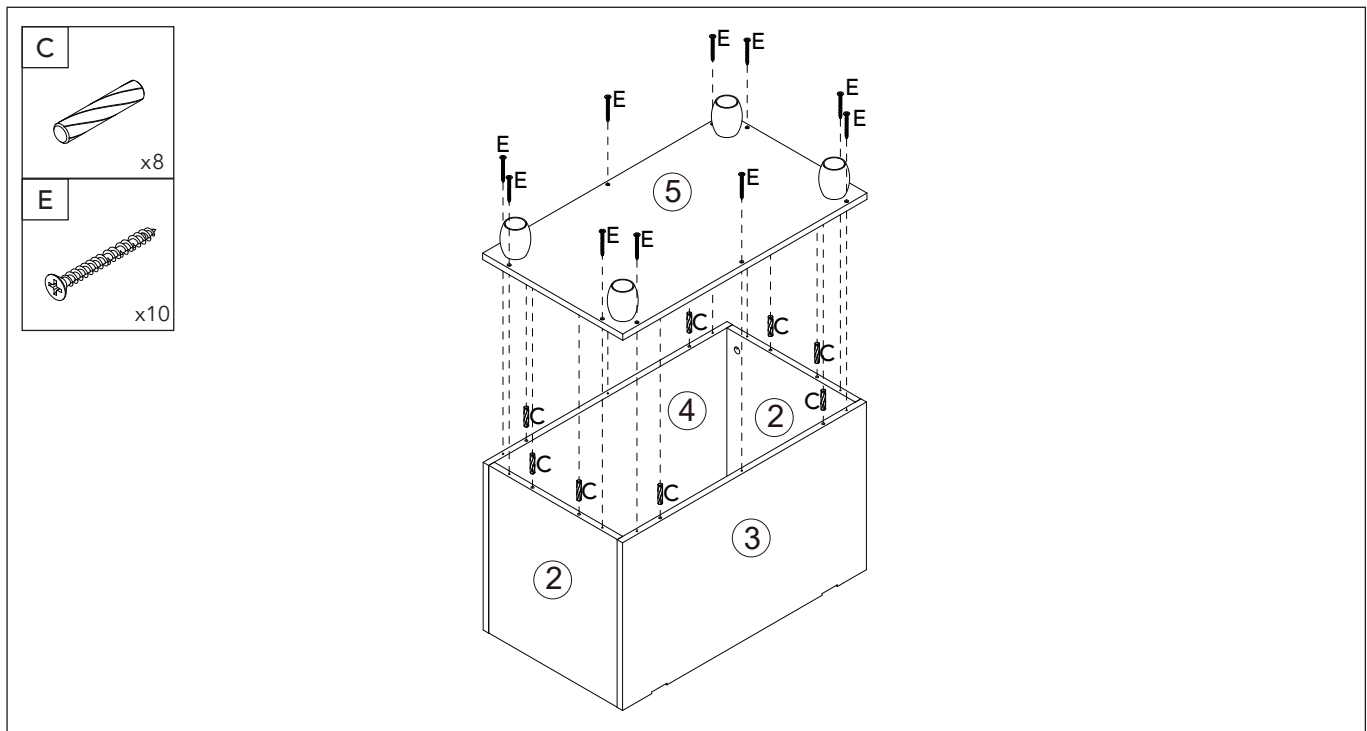

ASSEMBLY INSTRUCTIONS

STEP 5

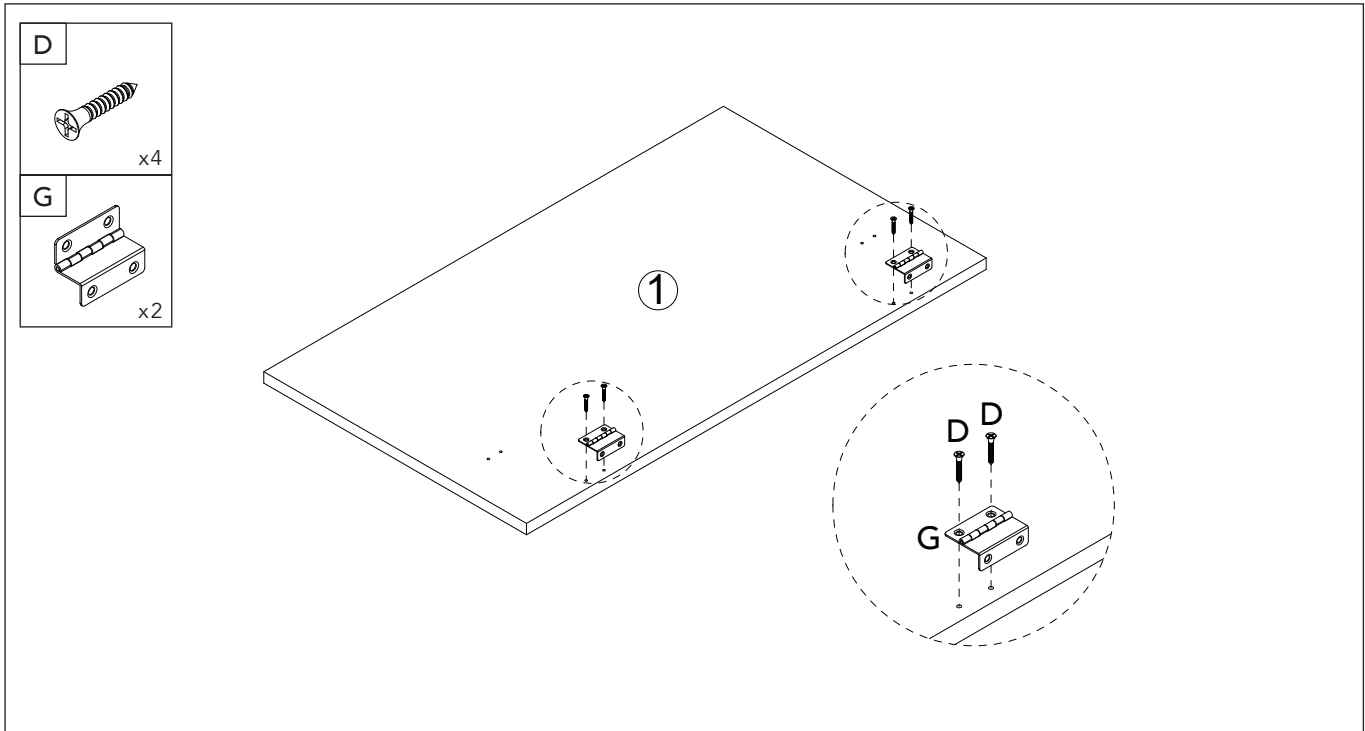

STEP 6

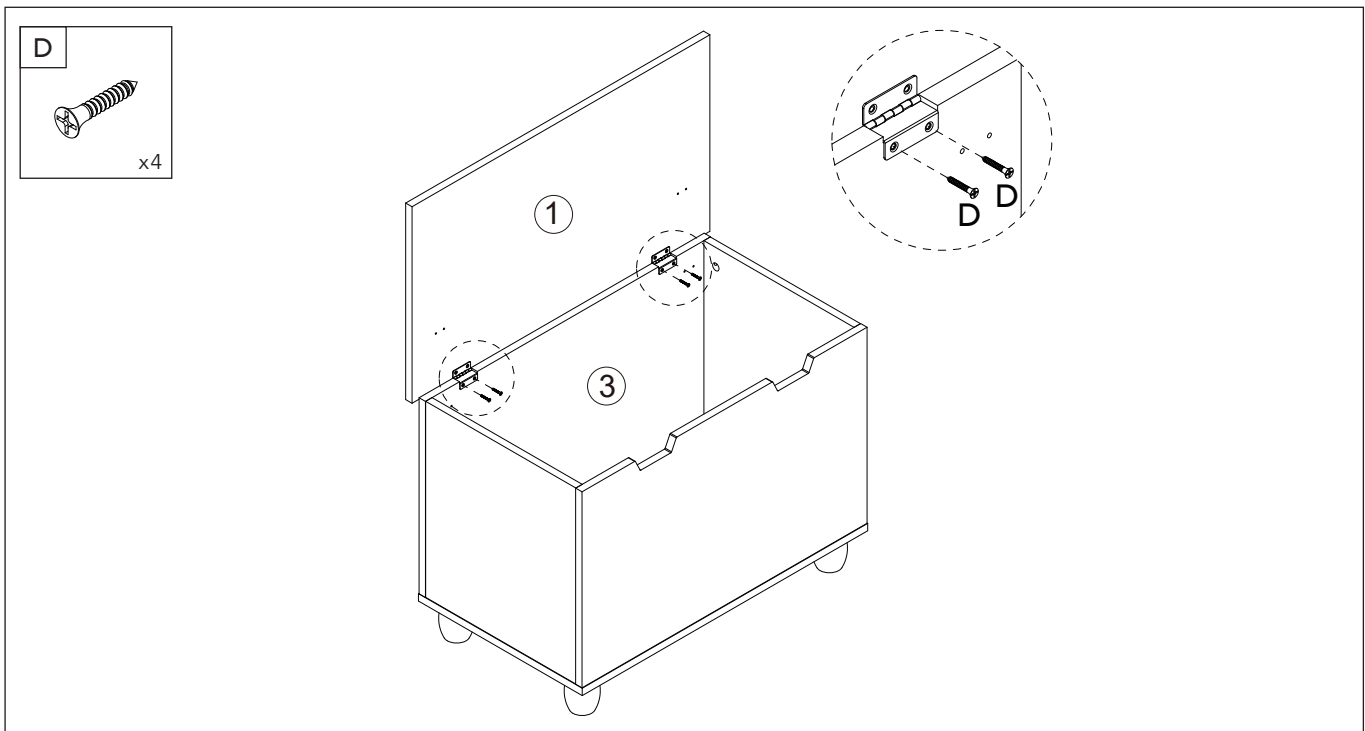

ASSEMBLY INSTRUCTIONS

STEP 7

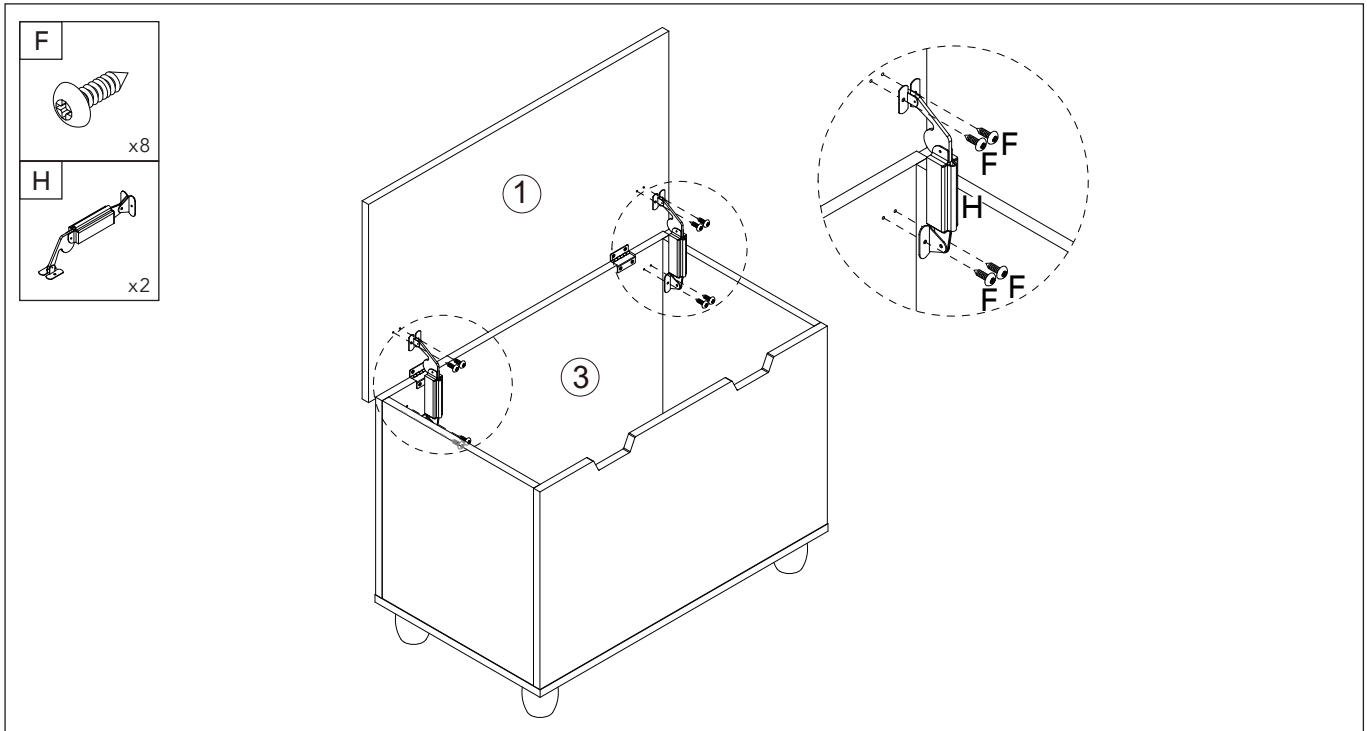

STEP 8

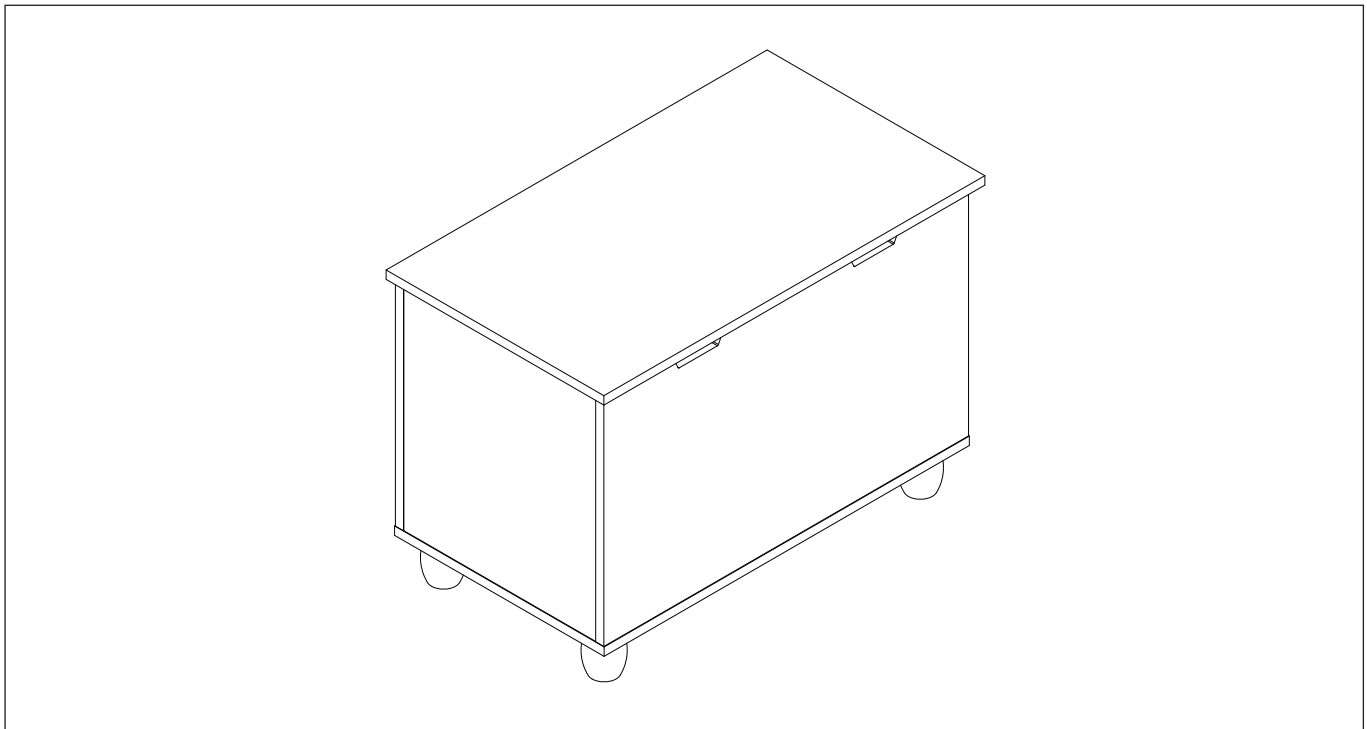

ASSEMBLY INSTRUCTIONS

RECOMMENDED WEIGHT

MAXIMUM RECOMMENDED WEIGHT IS 20KGs ON TOP AND 15KGs INSIDE EACH SHELF.

Your new product is ready for use.

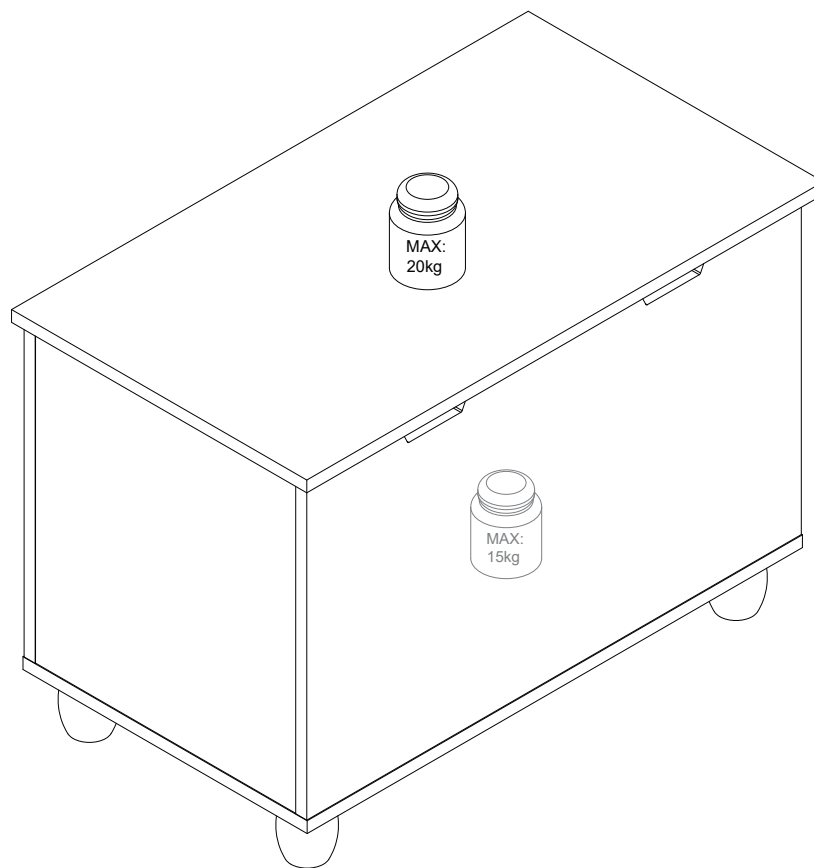

CARE & MAINTENANCE OF YOUR PRODUCT

Just a few simple steps to keep your furniture looking fabulous and functioning flawlessly:

- Please periodically check all fittings and re-tighten as necessary.
- To clean your item, please use a damp cloth and wipe clean.
- To clean glass, please use glass cleaner.
- Never allow any kind of liquid to remain on your furniture.
Absorption can cause wood to warp or finishes to de-laminate.
- Please do not place hot items (eg. hot drinks) directly on to the surface.
- Please do not drag and pull your furniture.

WARRANTY

Cooper & Co products are warranted to be free from defects in materials and workmanship for the warranty period of 12 months from the date of retail sale. Our goods come with guarantees that cannot be excluded under the Australian Consumer Law. You are entitled to a replacement or refund for a major failure and for compensation for any other reasonably foreseeable loss or damage. You are also entitled to have the goods repaired or replaced if the goods fail to be of acceptable quality and the failure does not amount to a major failure.

Cooper & Co.

Cooper & Co products are waiting for you at:

www.cooperandco.com.au

Find us on Instagram at:

[cooperandco_australia](https://www.instagram.com/cooperandco_australia)